

Aluminum Spar (1/16 x 1/2 x 42.5 in)

The order for the spars in order from front of the plane to the back goes:
Aluminum Spar, S1, then S2

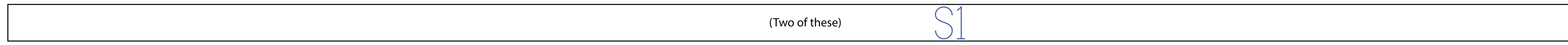

(Two of these)

Copyright ©2023 13thSquadron. All Rights Reserved.
Commercial use of our plans are prohibited.

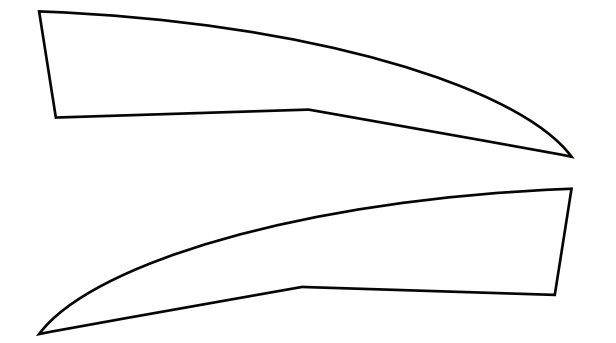
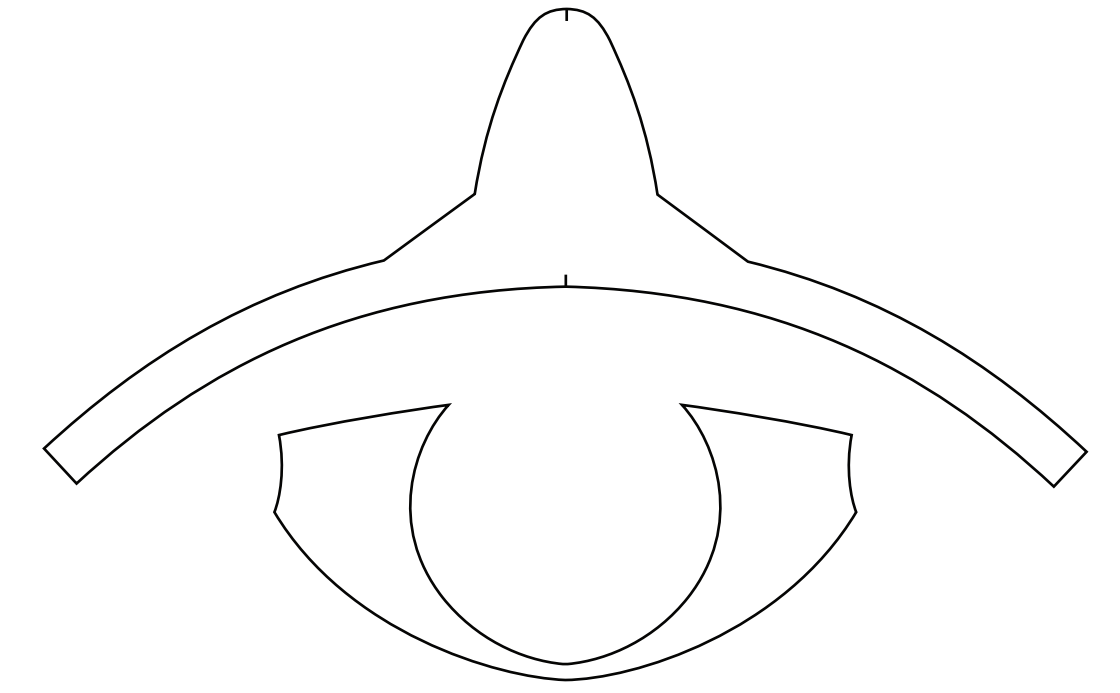

When mounting the firewall, know that the motor is three degrees to the right if your propeller is spinning counter-clockwise and vice versa.

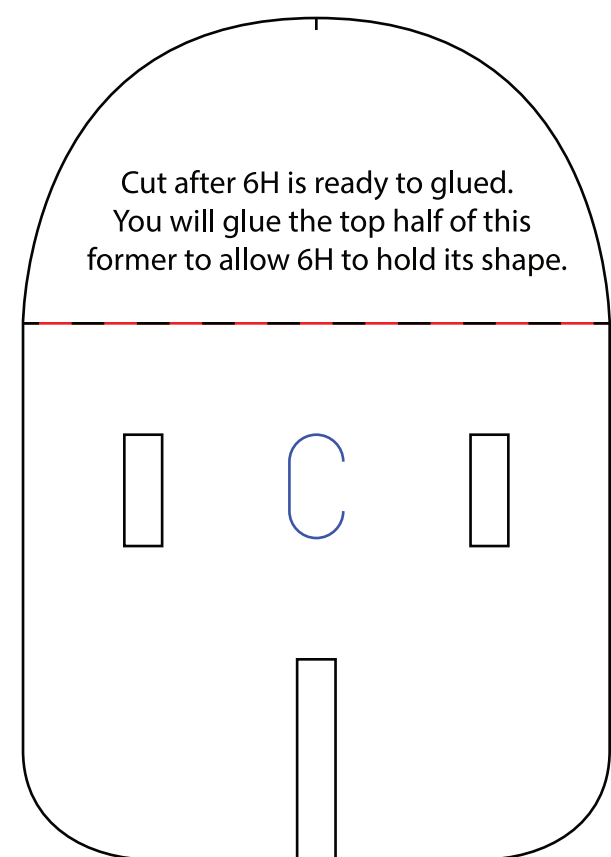
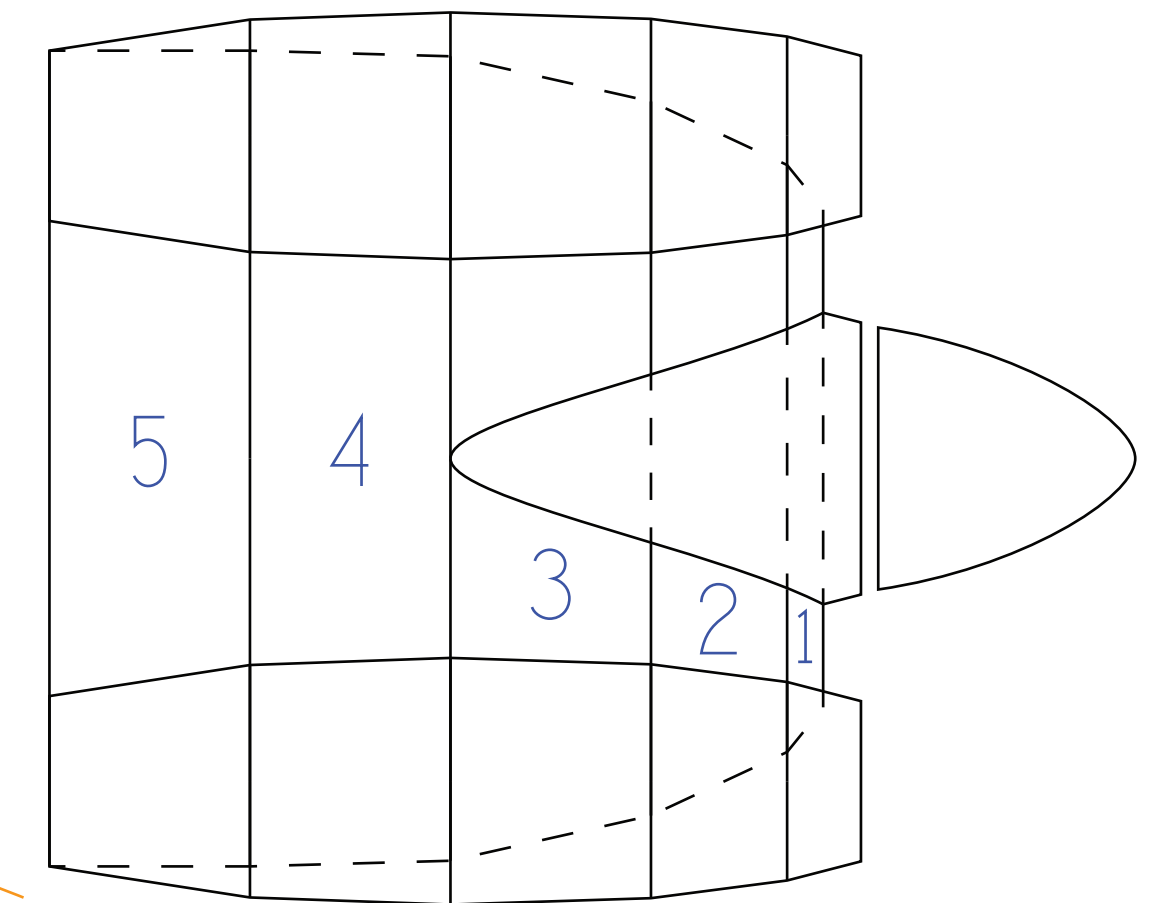
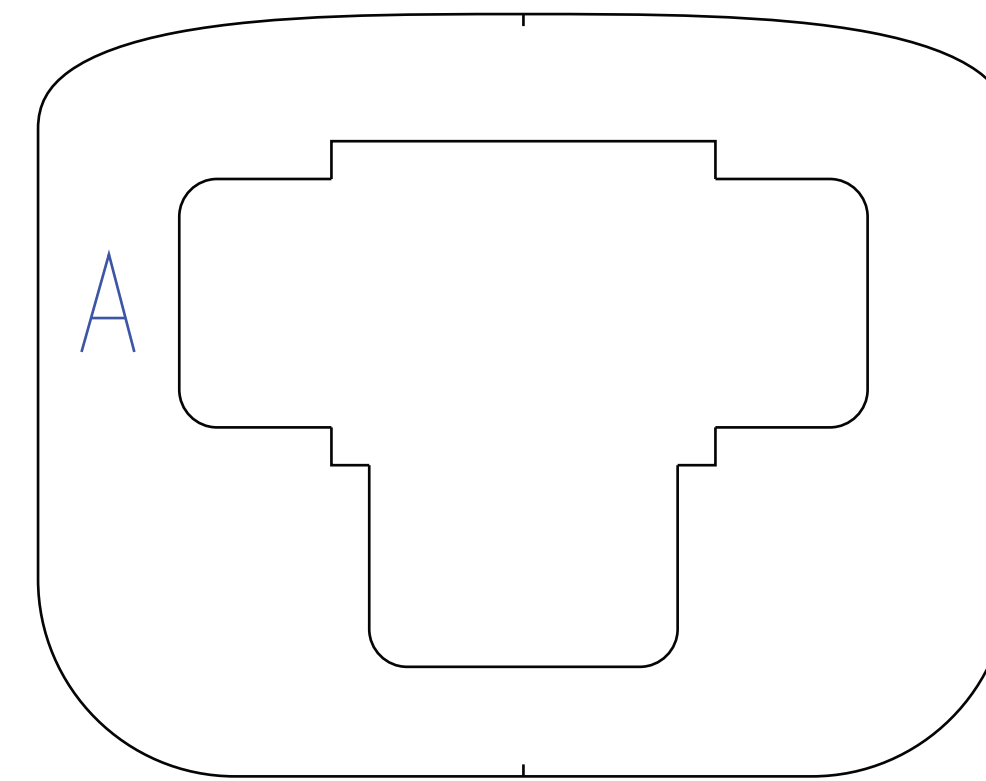
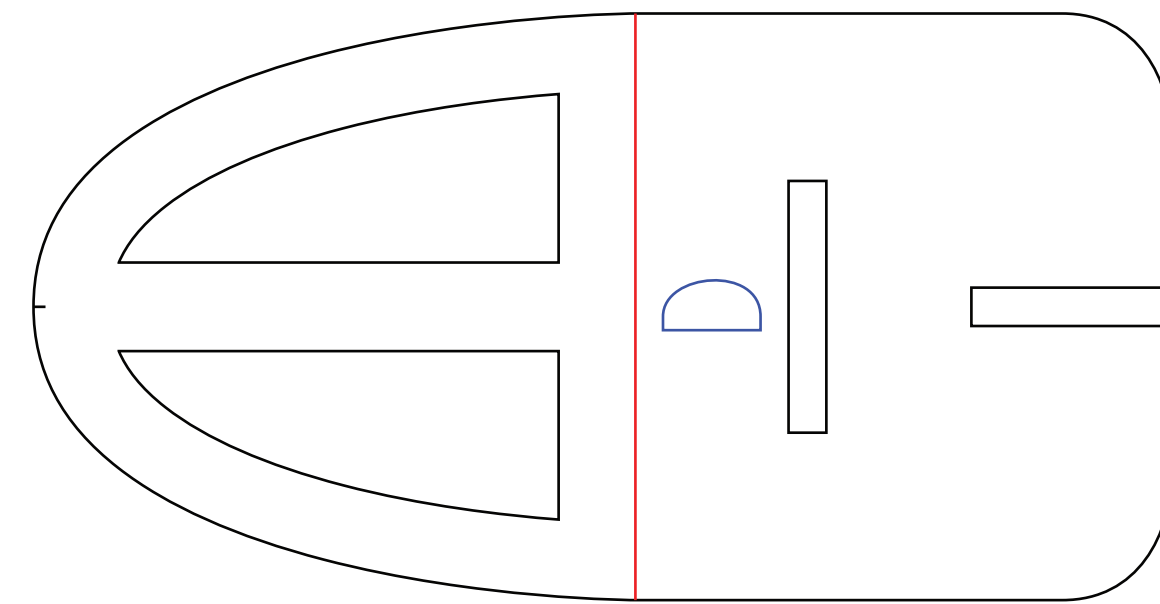
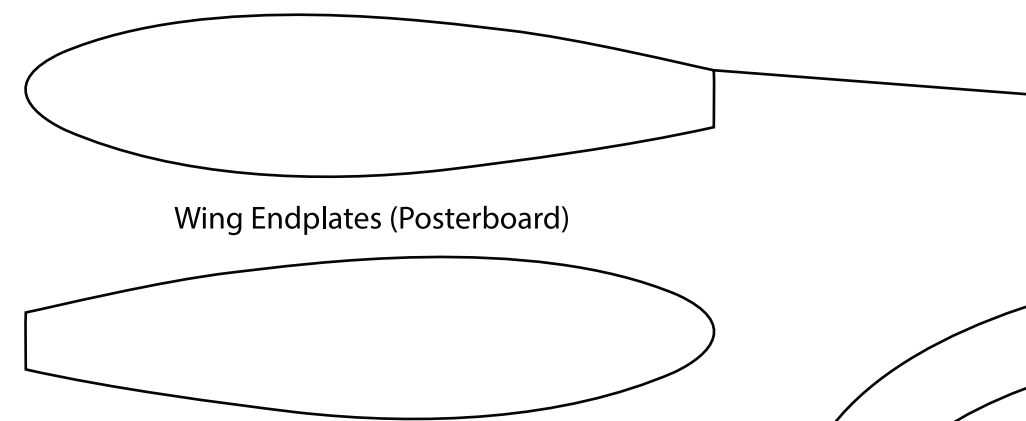
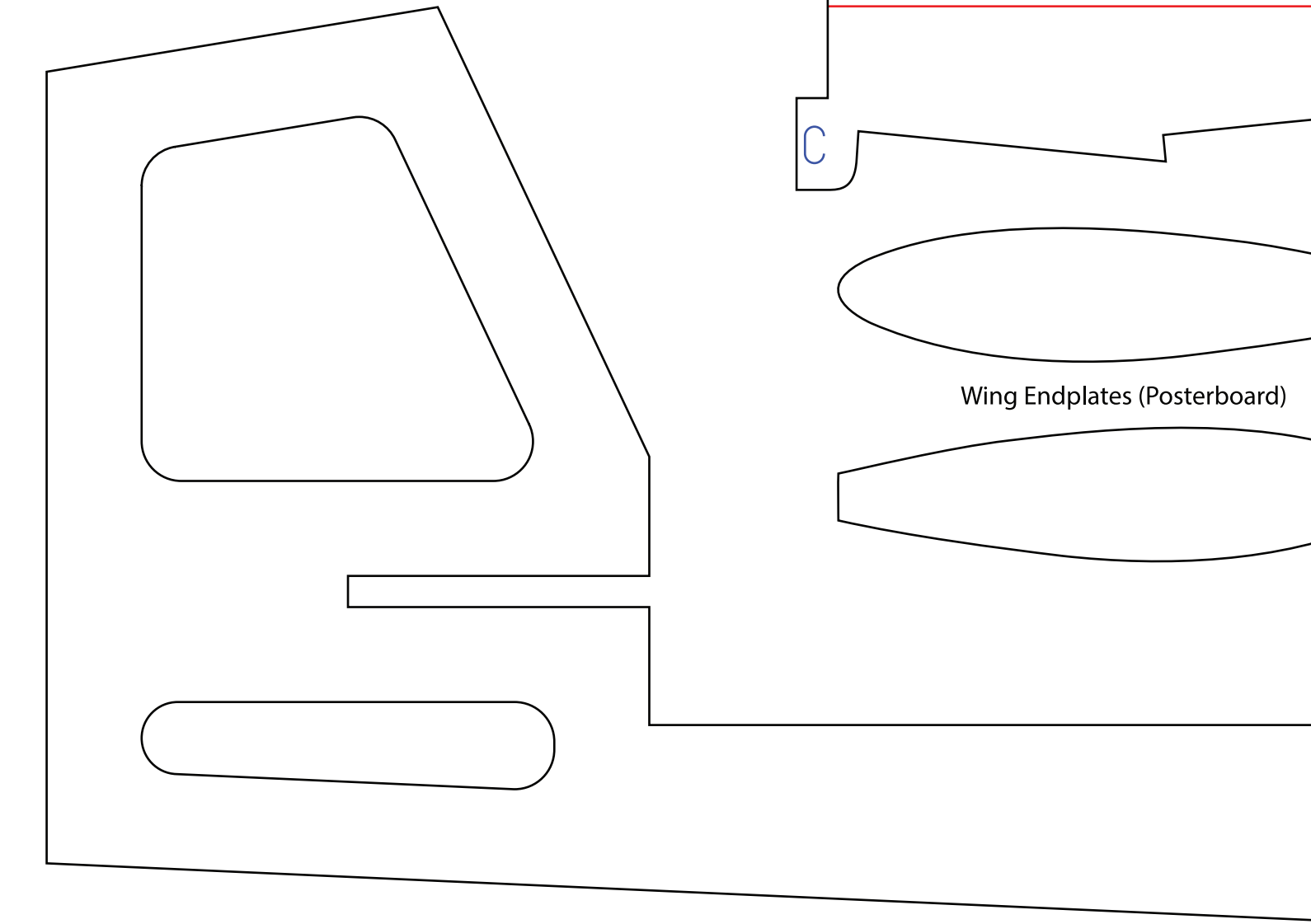
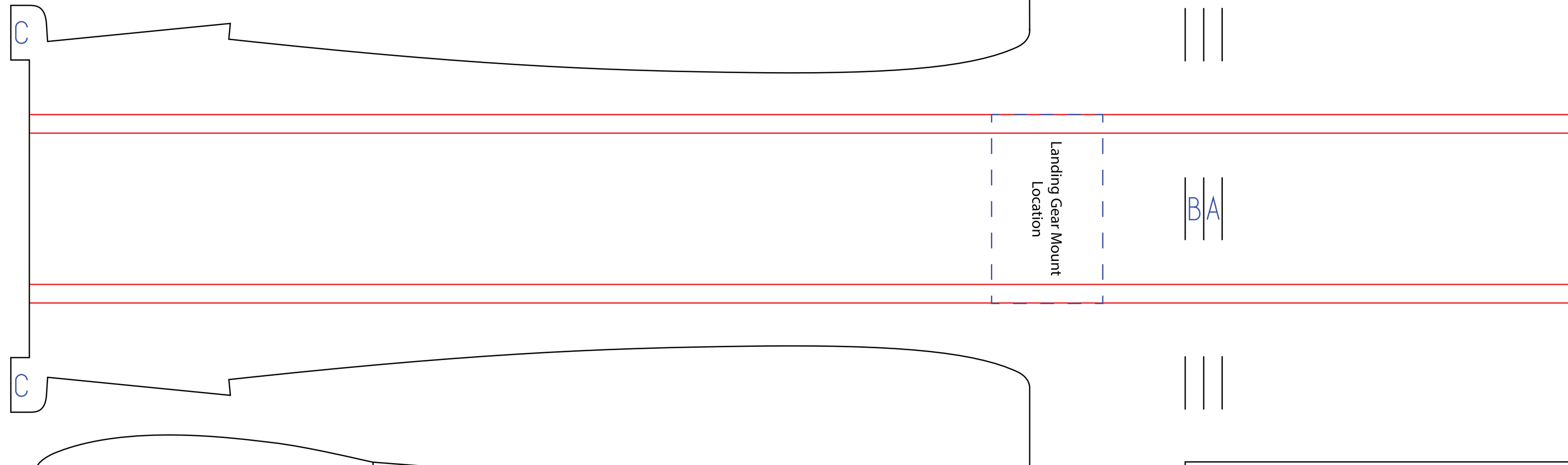
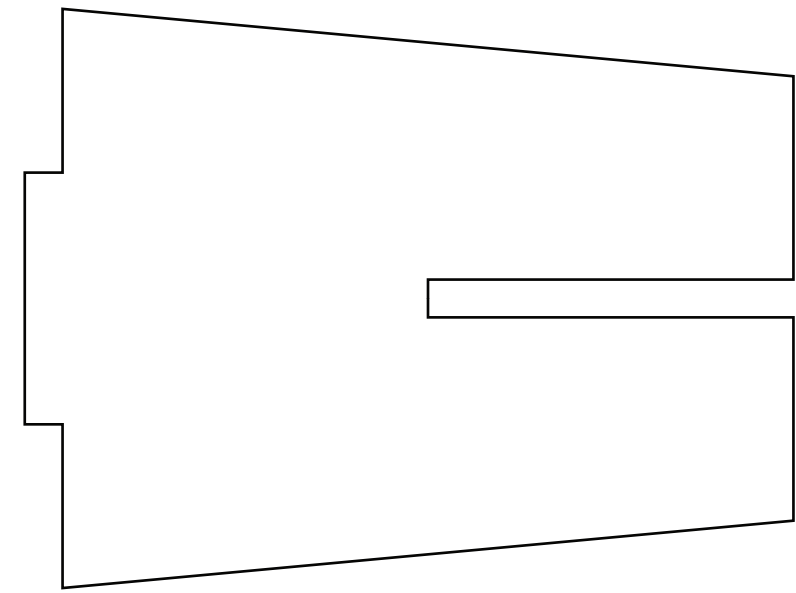
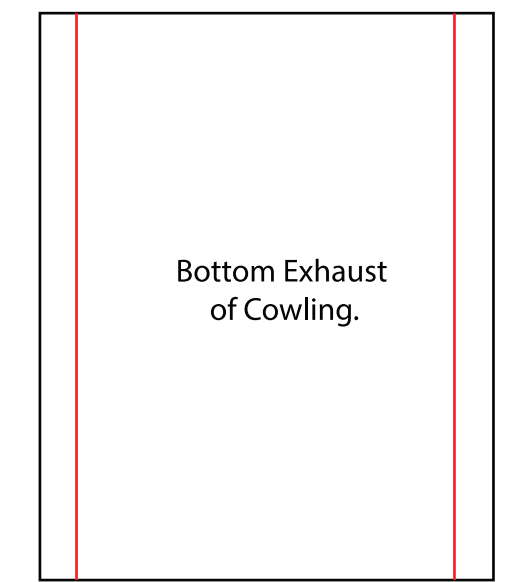

Cut after 6H is ready to glued.
You will glue the top half of this former to allow 6H to hold its shape.

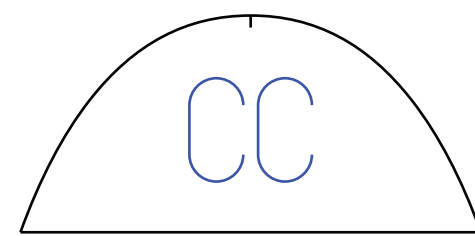

Former for C5 piece to give the canopy it's shape.

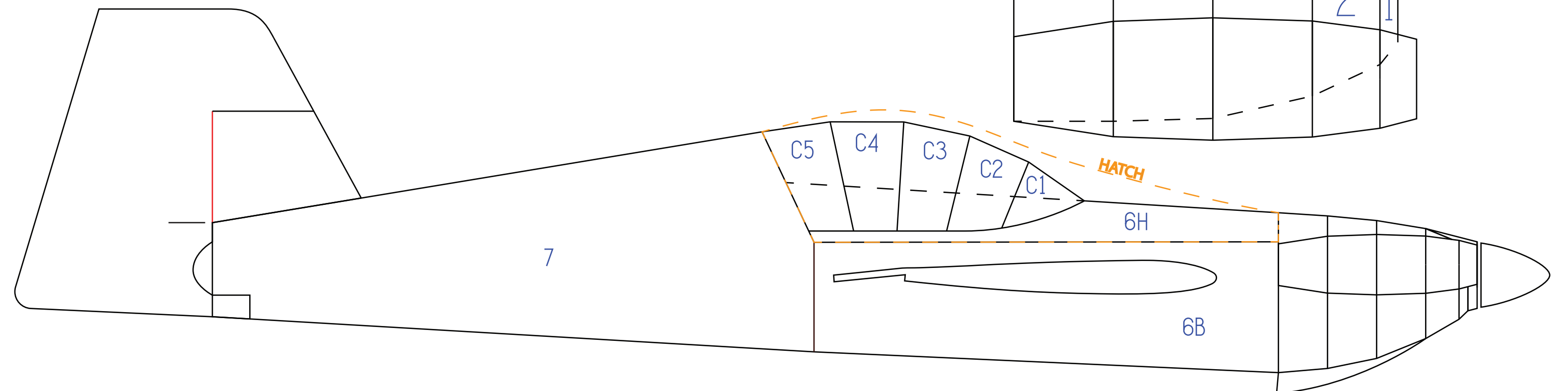
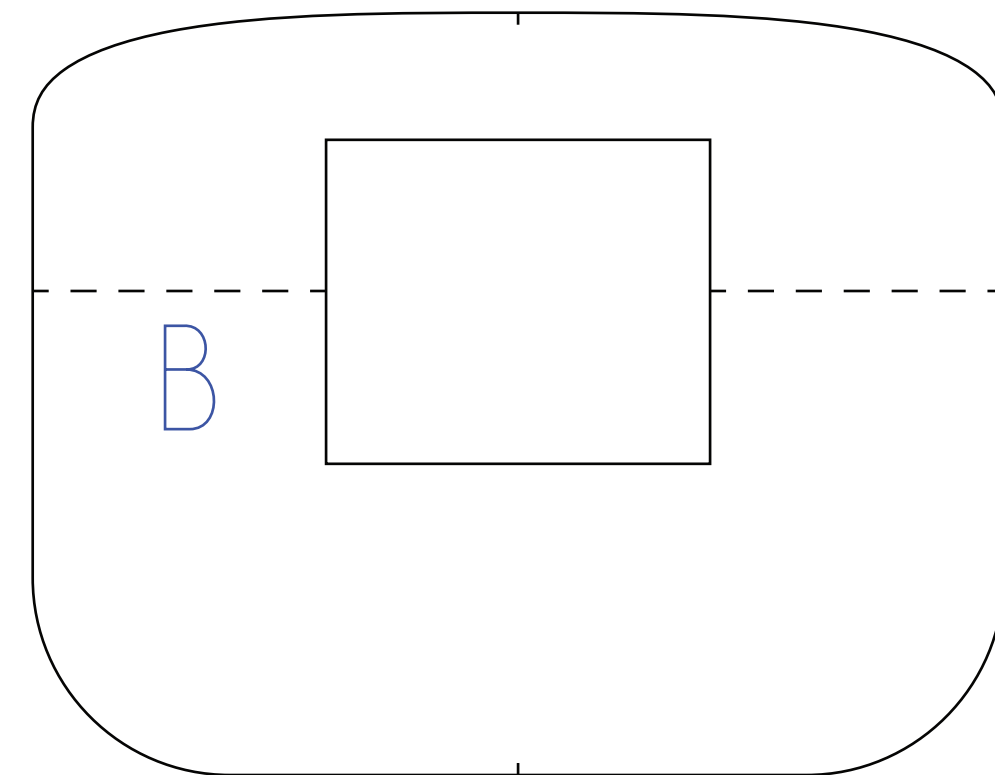

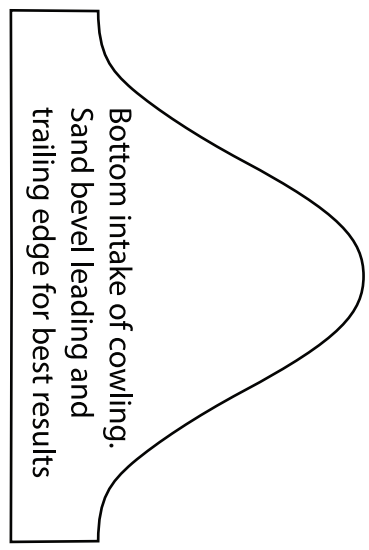
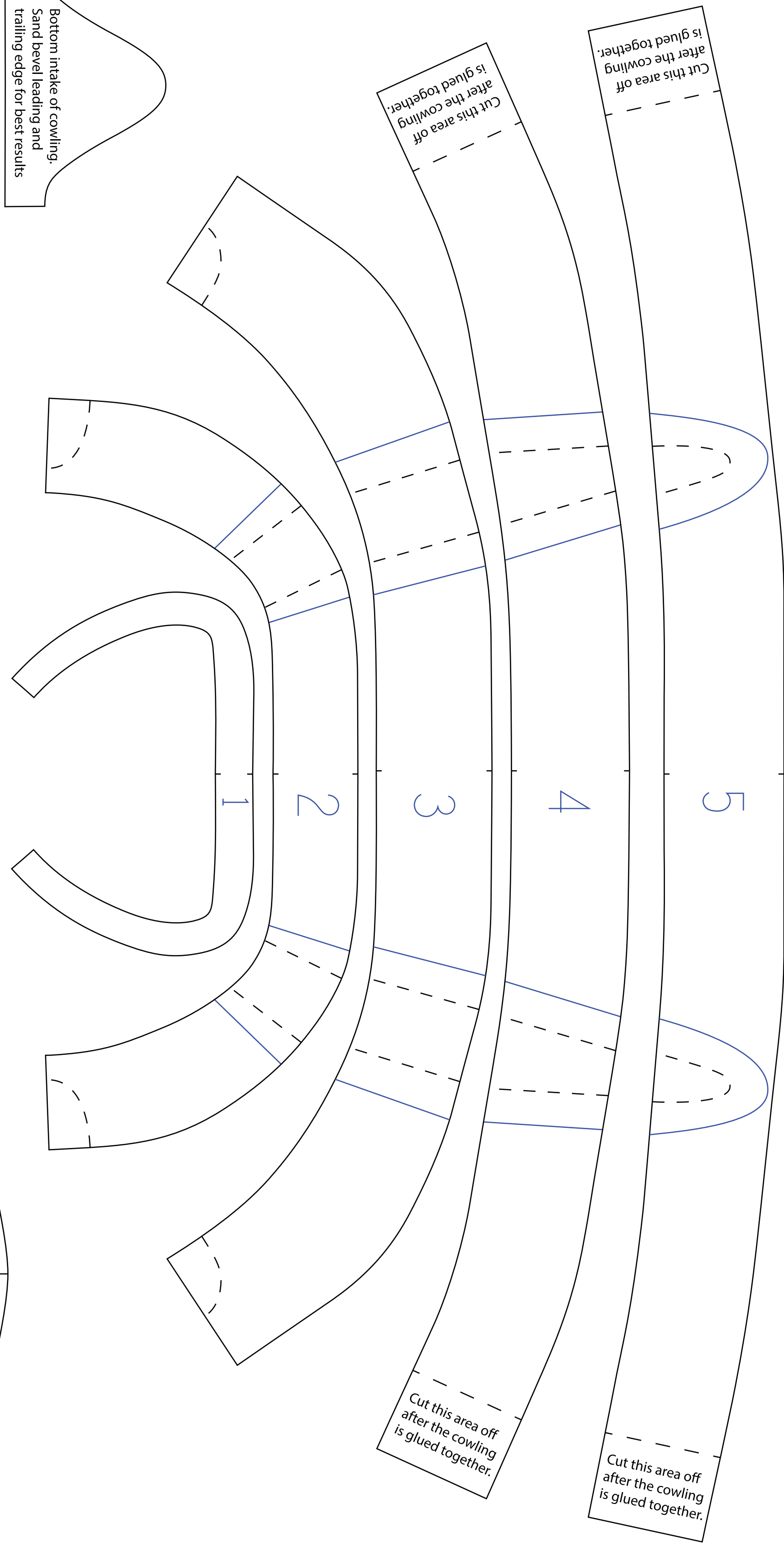

Bottom intake of cowling.
Sand bevel leading and trailing edge for best results

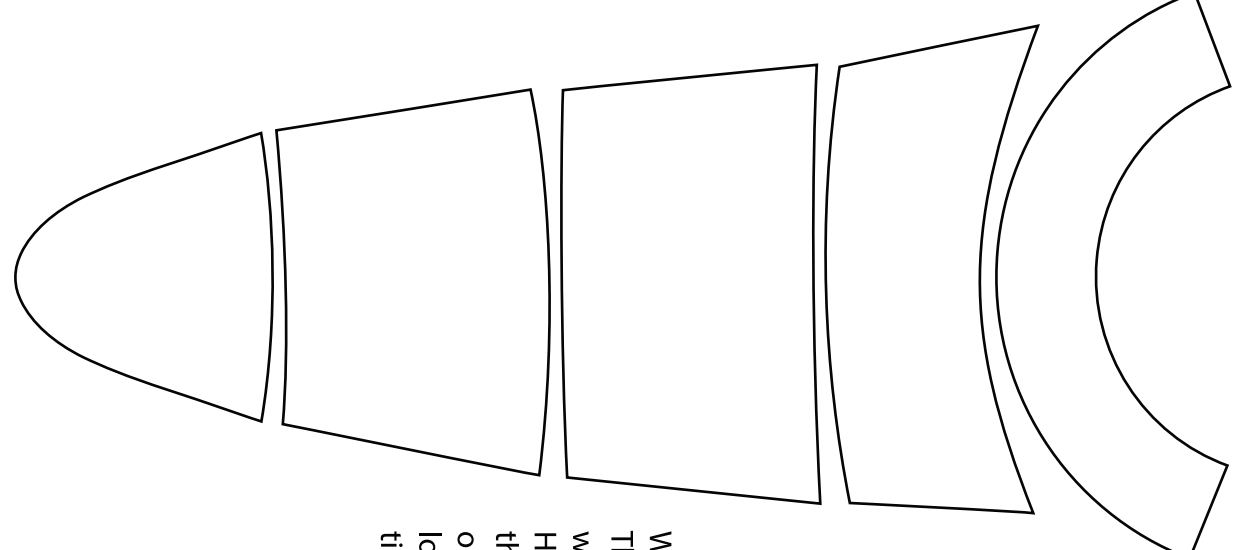

From the cockpit's perspective
Left side

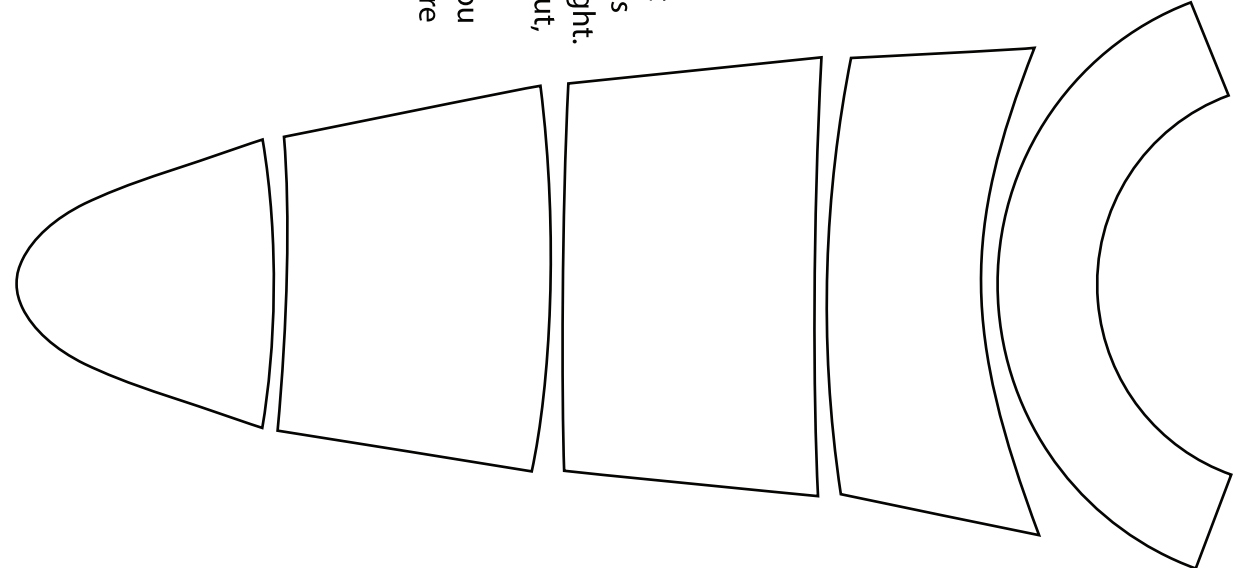

From the cockpit's perspective
Right side

With these two side intakes, know that they are slightly different on each side which is why I labeled them left and right. However, when you cut these pieces out these pieces get glued together in the orientation they are here. As long as you look at reference photos and take your time they will turn out beautiful.

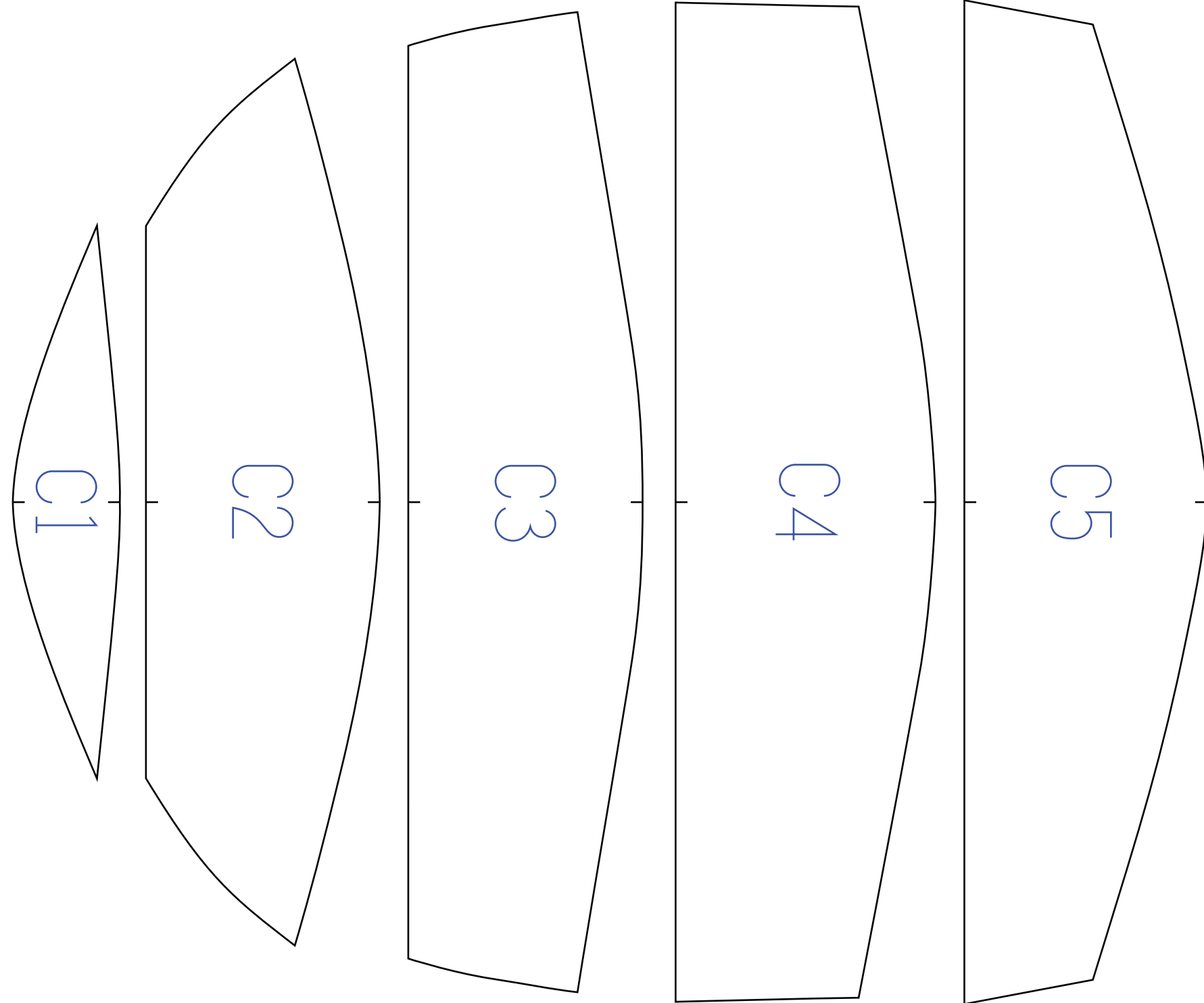

Copyright ©2023 13thSquadron. All Rights Reserved.
Commercial use of our plans are prohibited.

Barbecue Skewer

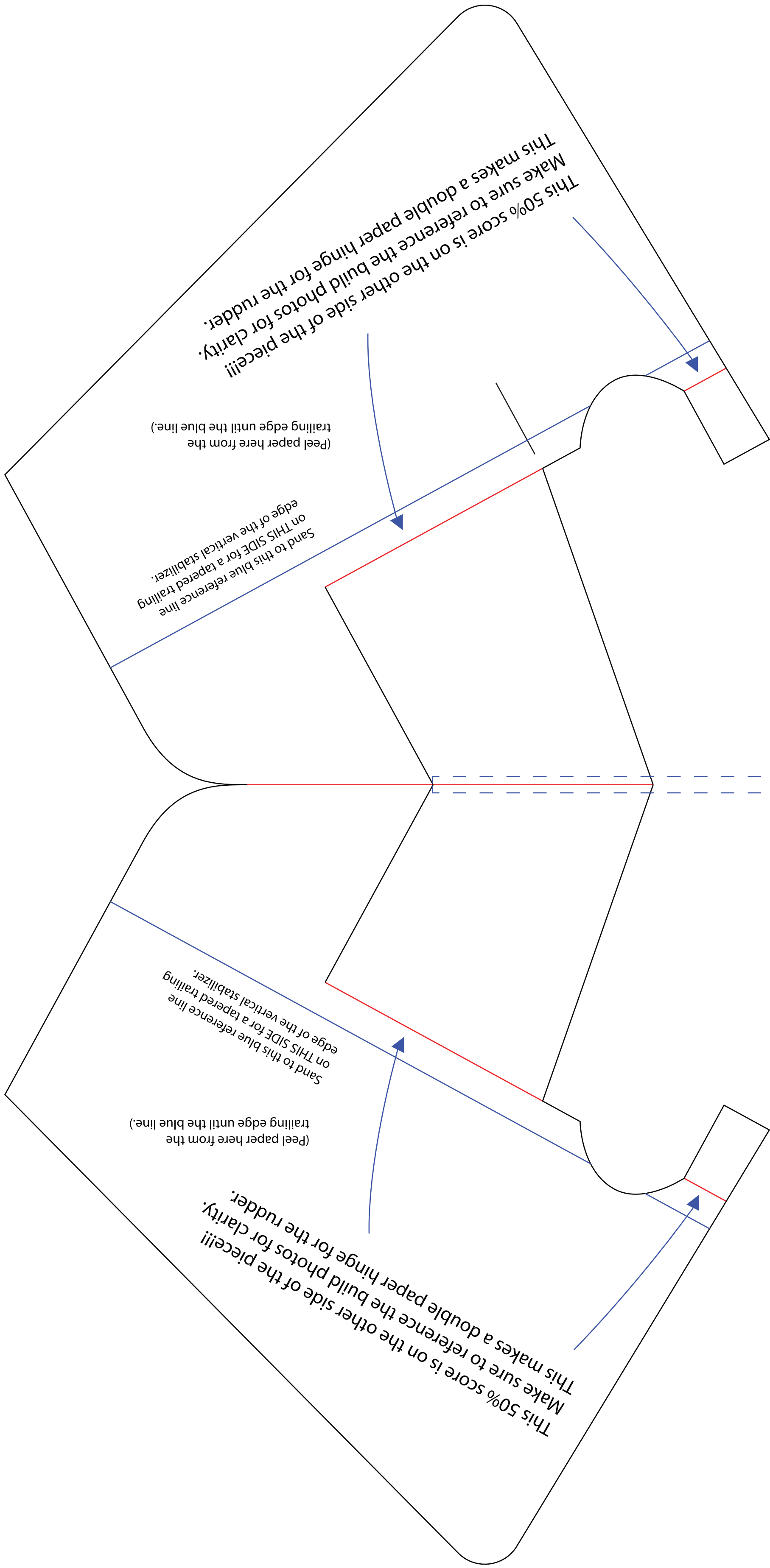

This 50% score is on the other side of the piece!!!
Make sure to reference the build photos for clarity.
This makes a double paper hinge for the rudder.

(Peel paper here from the trailing edge until the blue line.)
Sand to this blue reference line on THIS SIDE for a tapered trailing edge of the vertical stabilizer.

(Peel paper here from the trailing edge until the blue line.)
Sand to this blue reference line on THIS SIDE for a tapered trailing edge of the vertical stabilizer.

This 50% score is on the other side of the piece!!!
Make sure to reference the build photos for clarity.
This makes a double paper hinge for the rudder.

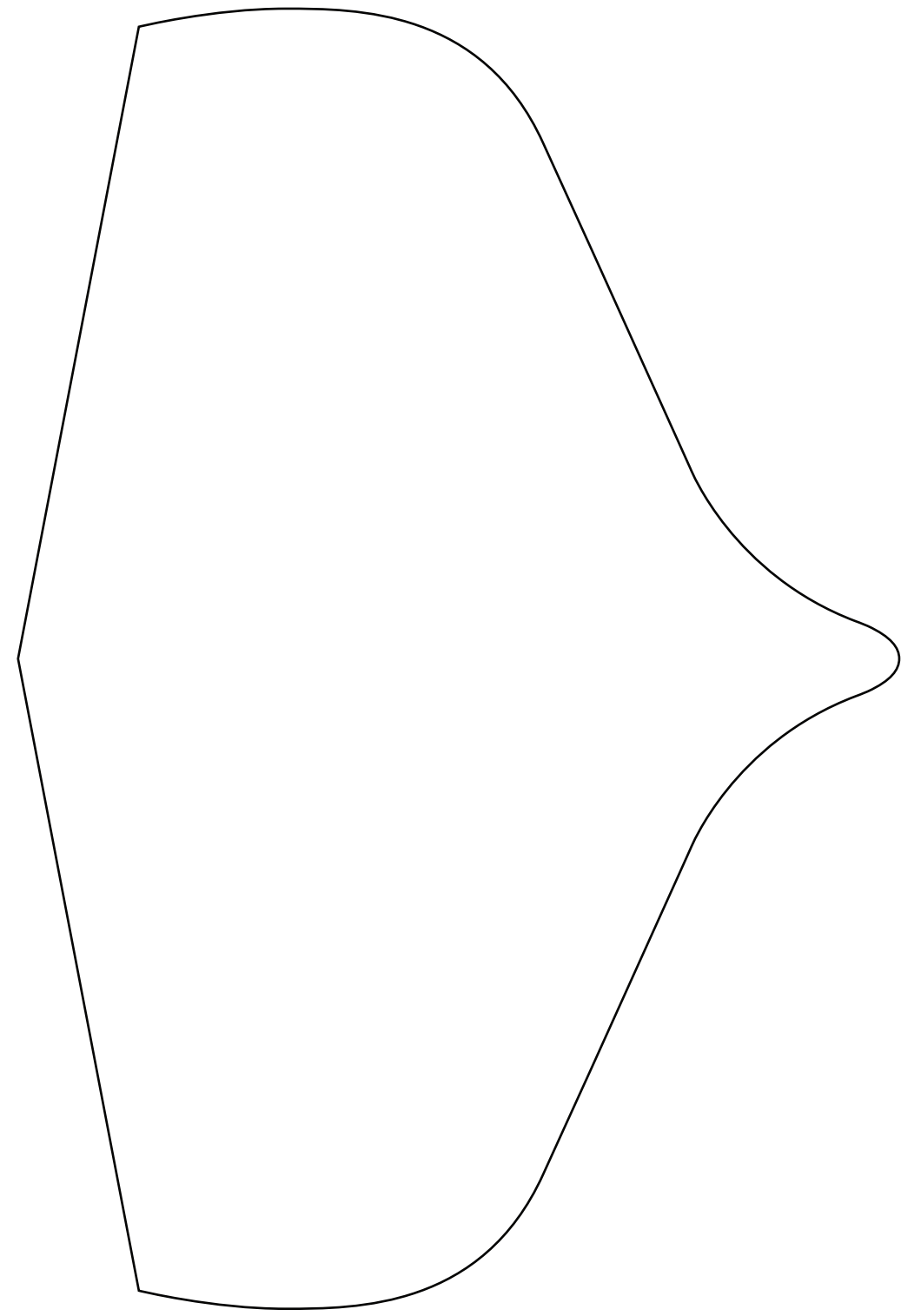

How to do the Leading Edges of the wings and elevator.

1. If the leading edge is separated, start here.
2. If the leading edge is not separated, start here.
3. Apply hot glue into the seam.
- 4.

This blue/red reference line is for you to bevel to allow more throw for the aileron and to make sure the bottom trailing edge lines up with. This makes sure that your wing is symmetrical and even on both sides.

Peel paper up till this line.

(Leave paper here)

Copyright ©2023 13thSquadron. All Rights Reserved.
Commercial use of our plans are prohibited.

Peel all the paper off here.

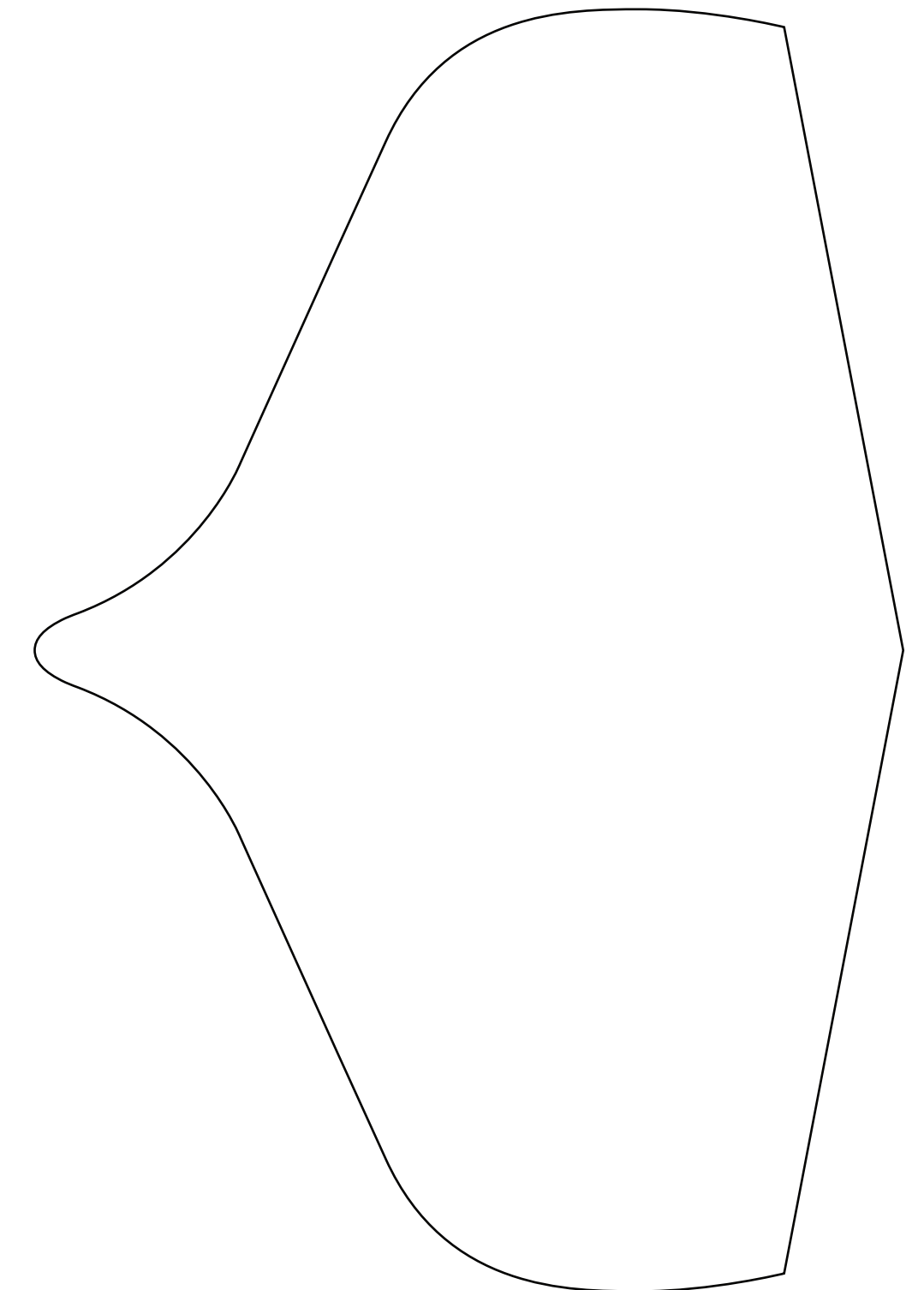

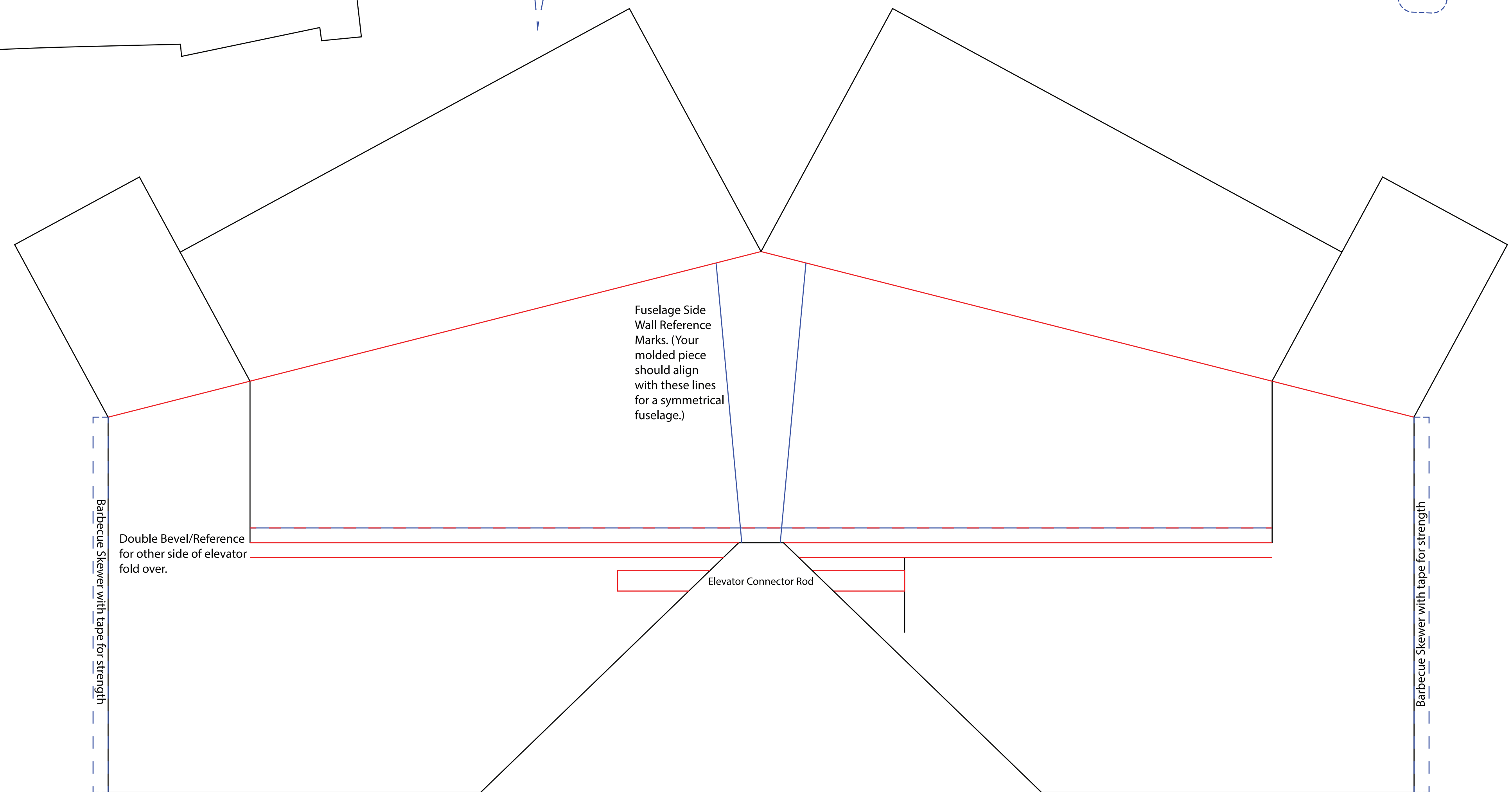
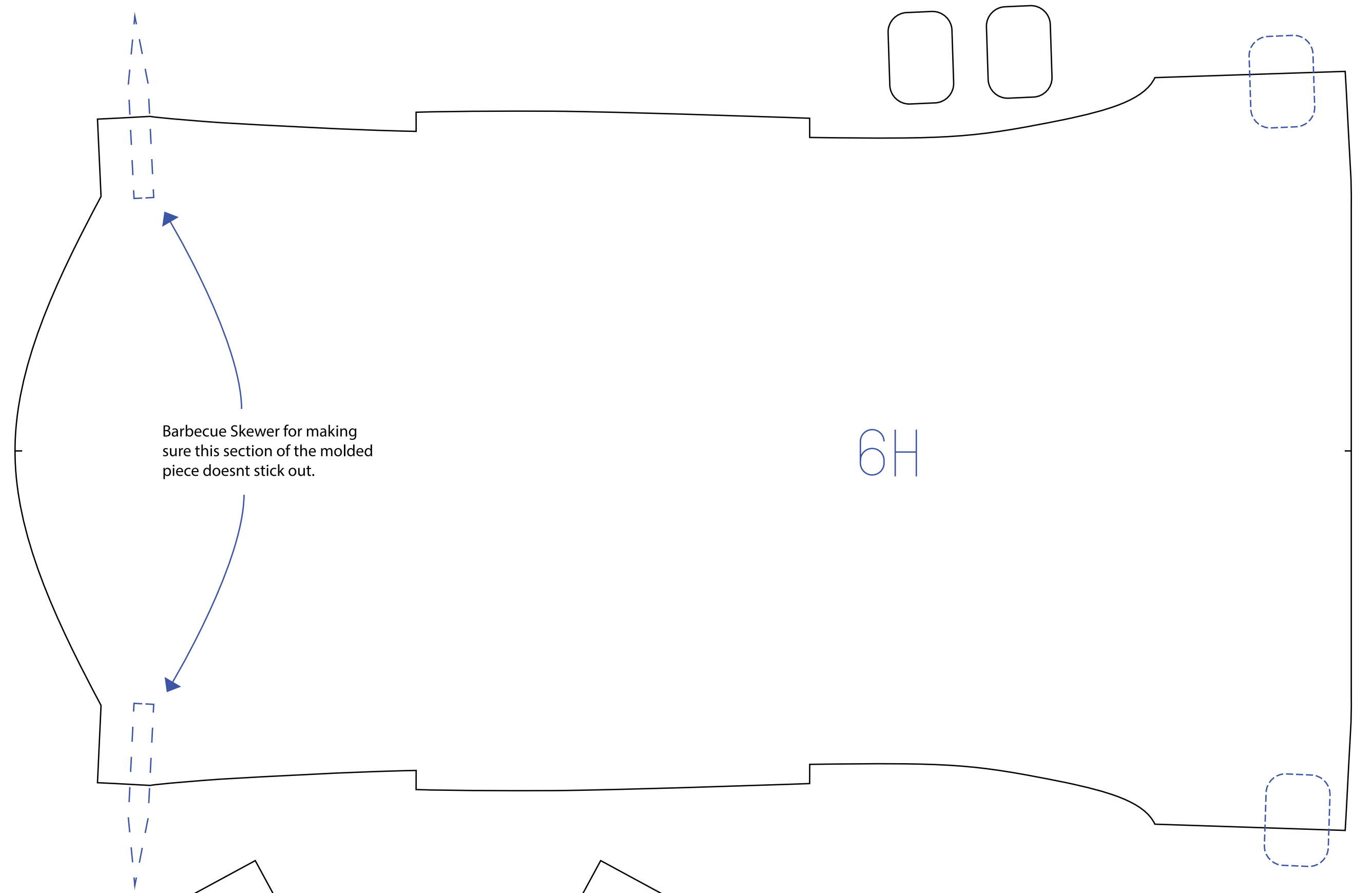
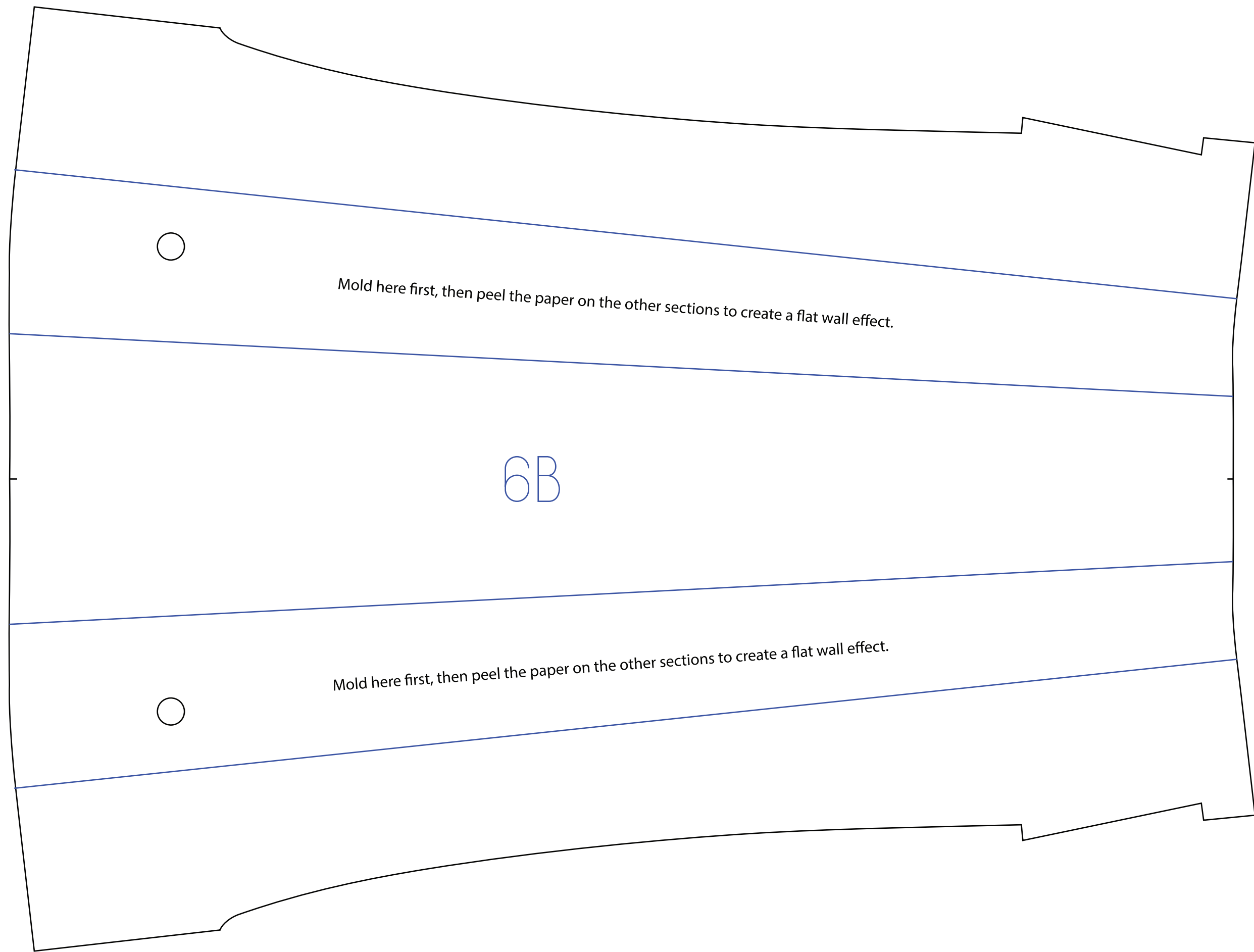

Copyright ©2023 13thSquadron. All Rights Reserved.
Commercial use of our plans are prohibited.

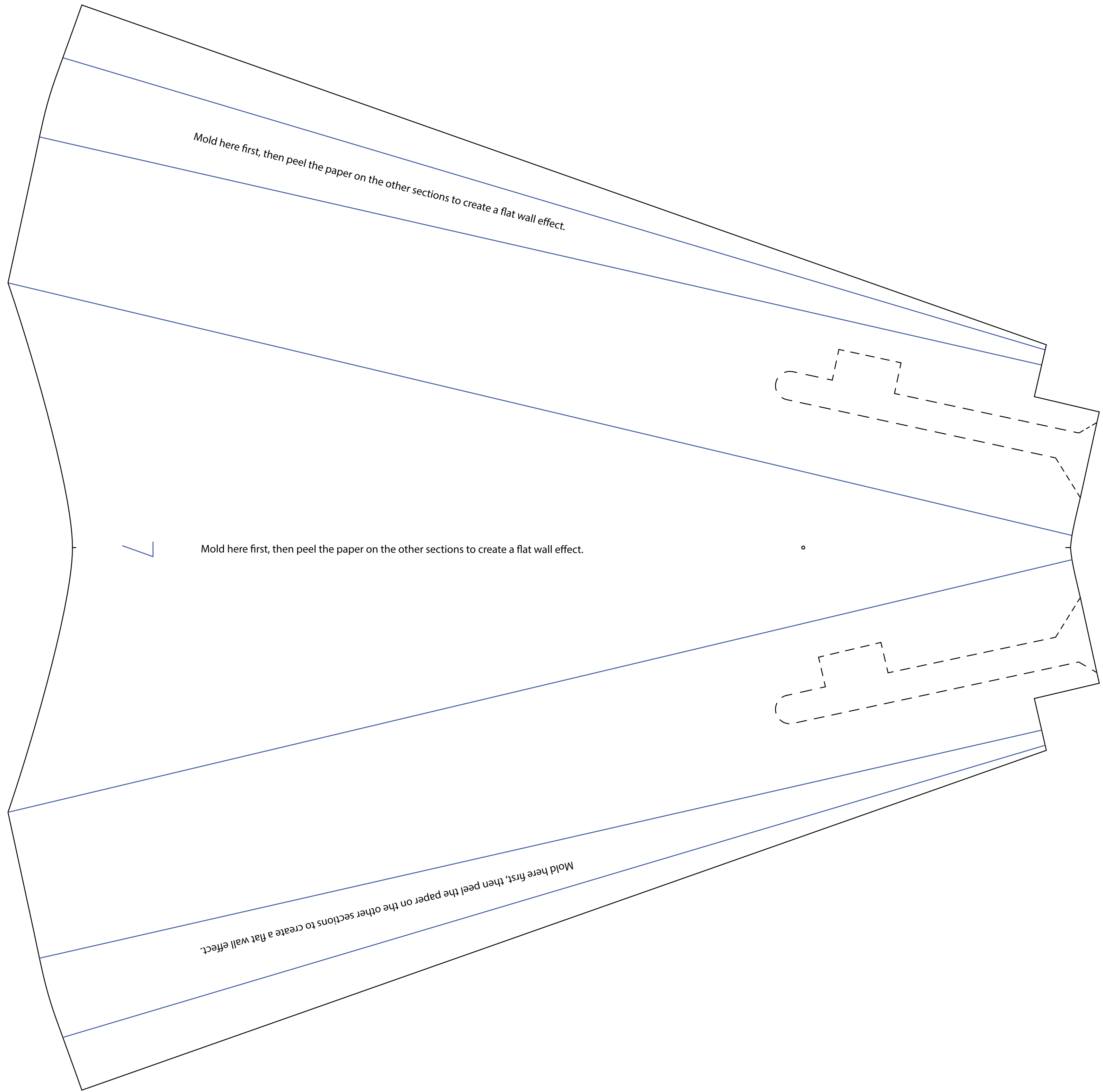

Mold here first, then peel the paper on the other sections to create a flat wall effect.

Mold here first, then peel the paper on the other sections to create a flat wall effect.

Mold here first, then peel the paper on the other sections to create a flat wall effect.

Copyright ©2023 13thSquadron. All Rights Reserved.
Commercial use of our plans are prohibited.