

45° Bevel

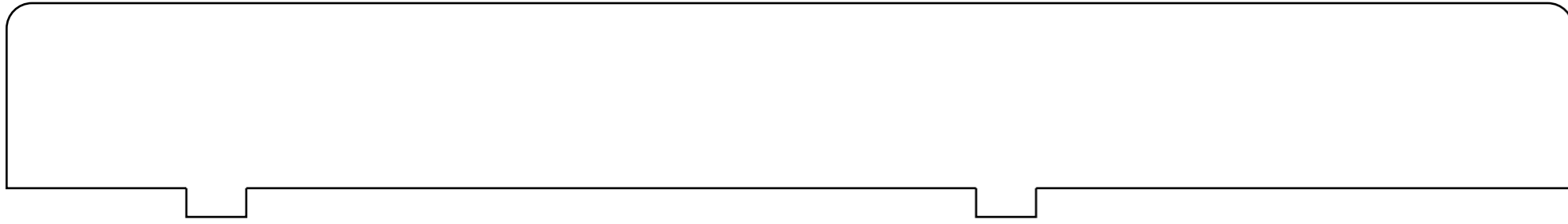

Flop this wing for the other side.



Once these two pieces are glued in an upside down "T", it gets glued here.

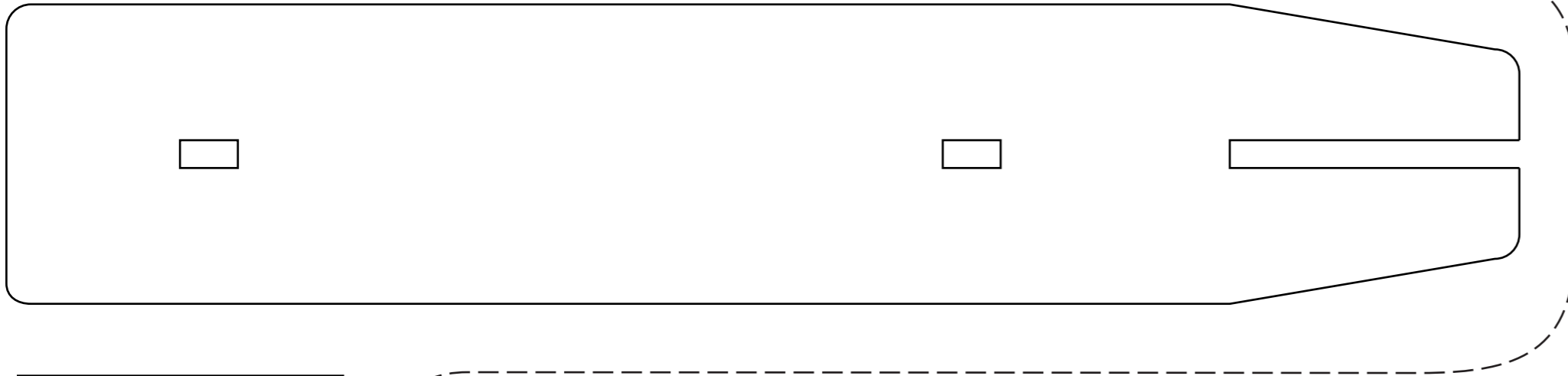

Side View of Top Air Scoop

Trim the foam here on the top piece of the Air scoop to help give it its shape.

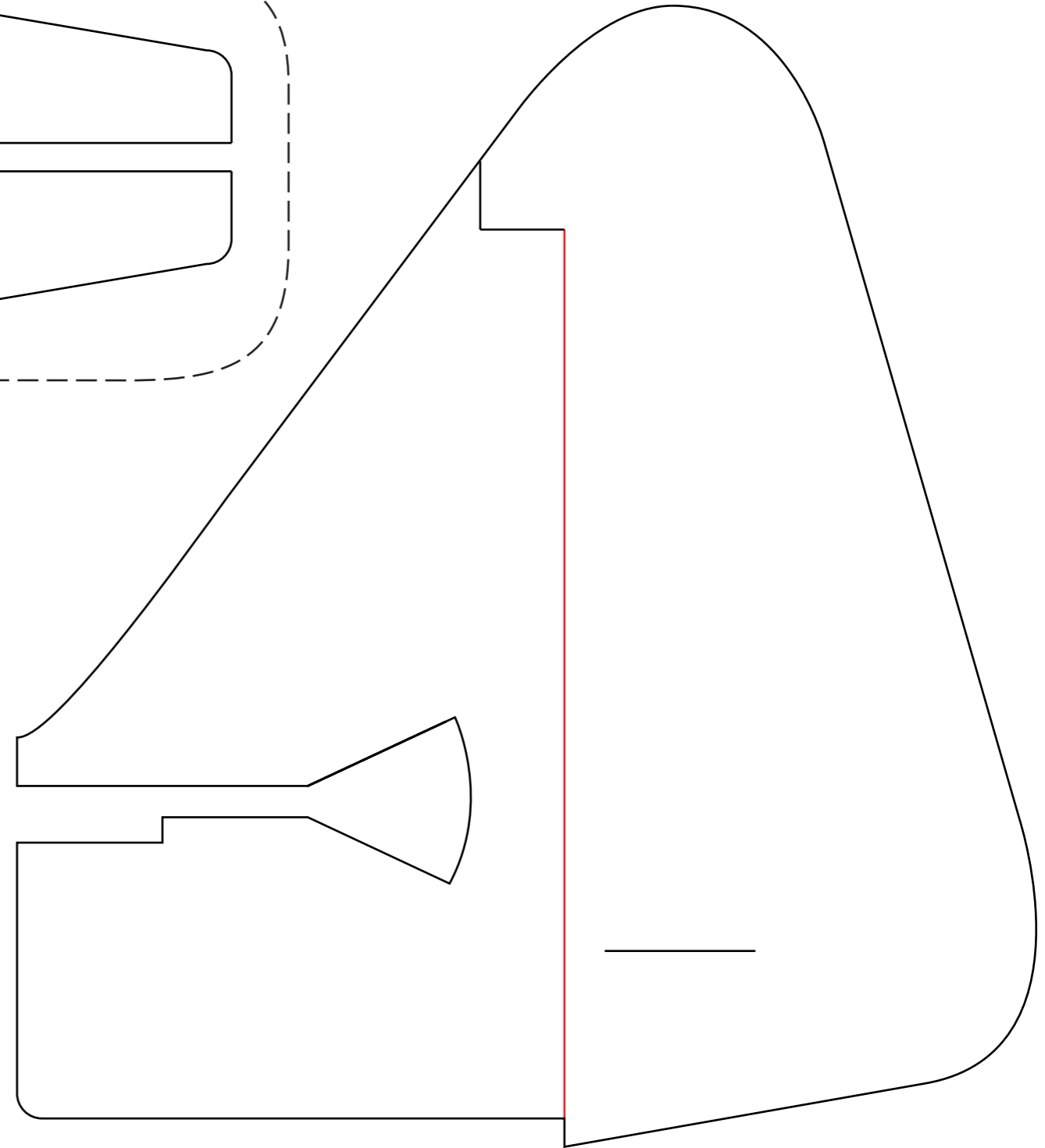
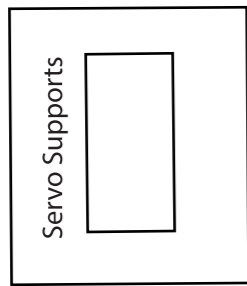
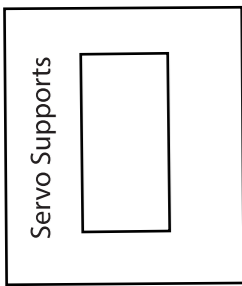
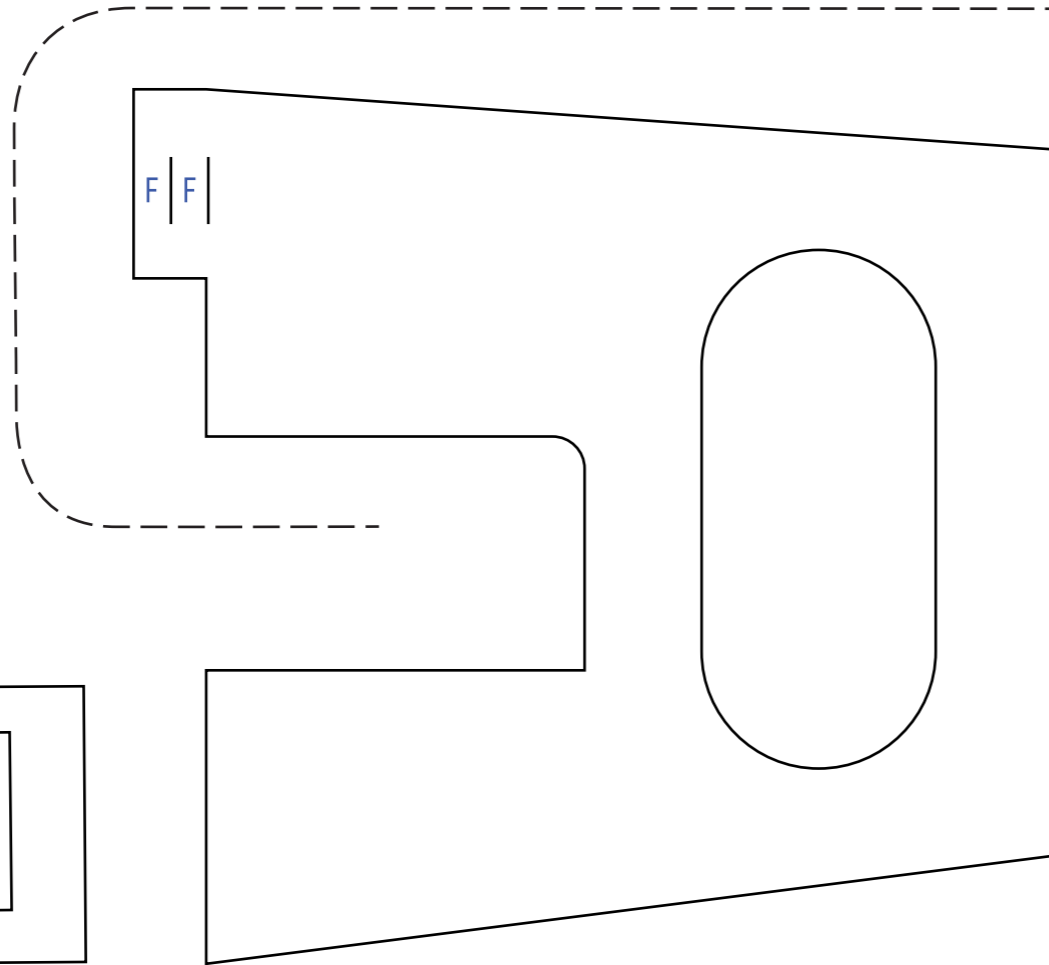
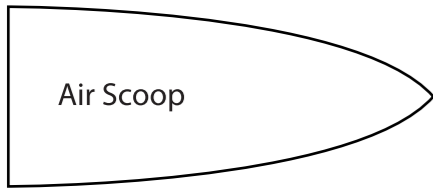
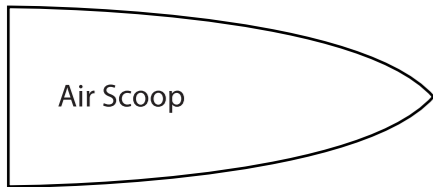

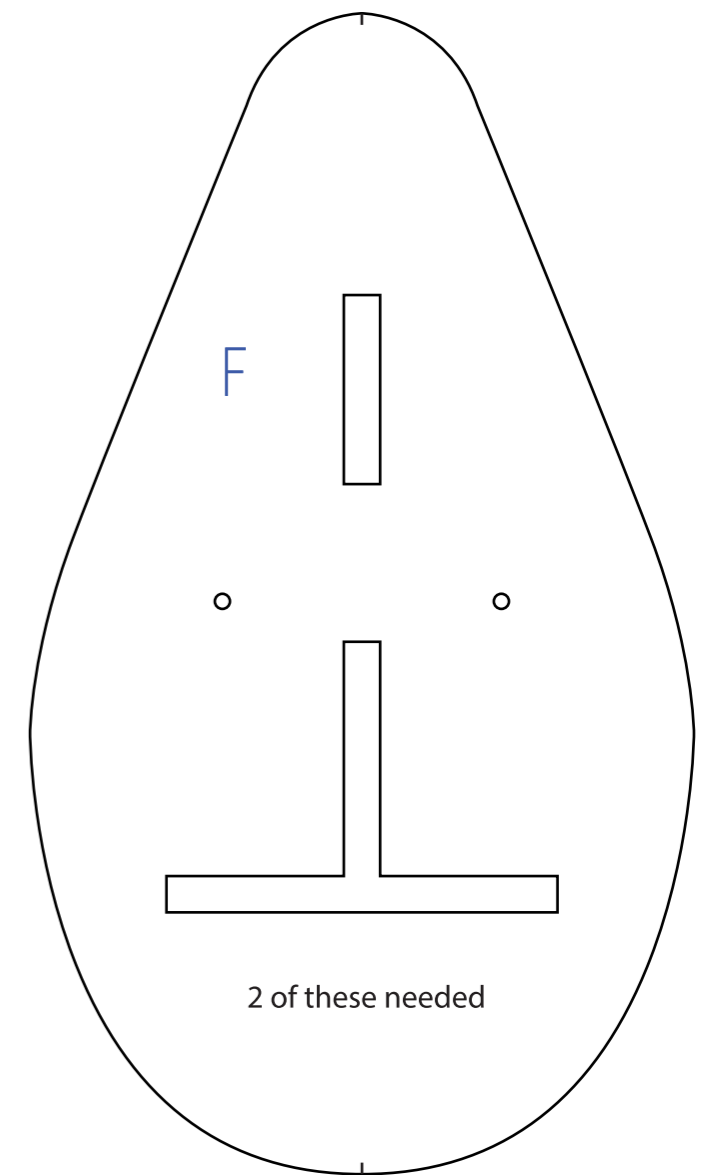
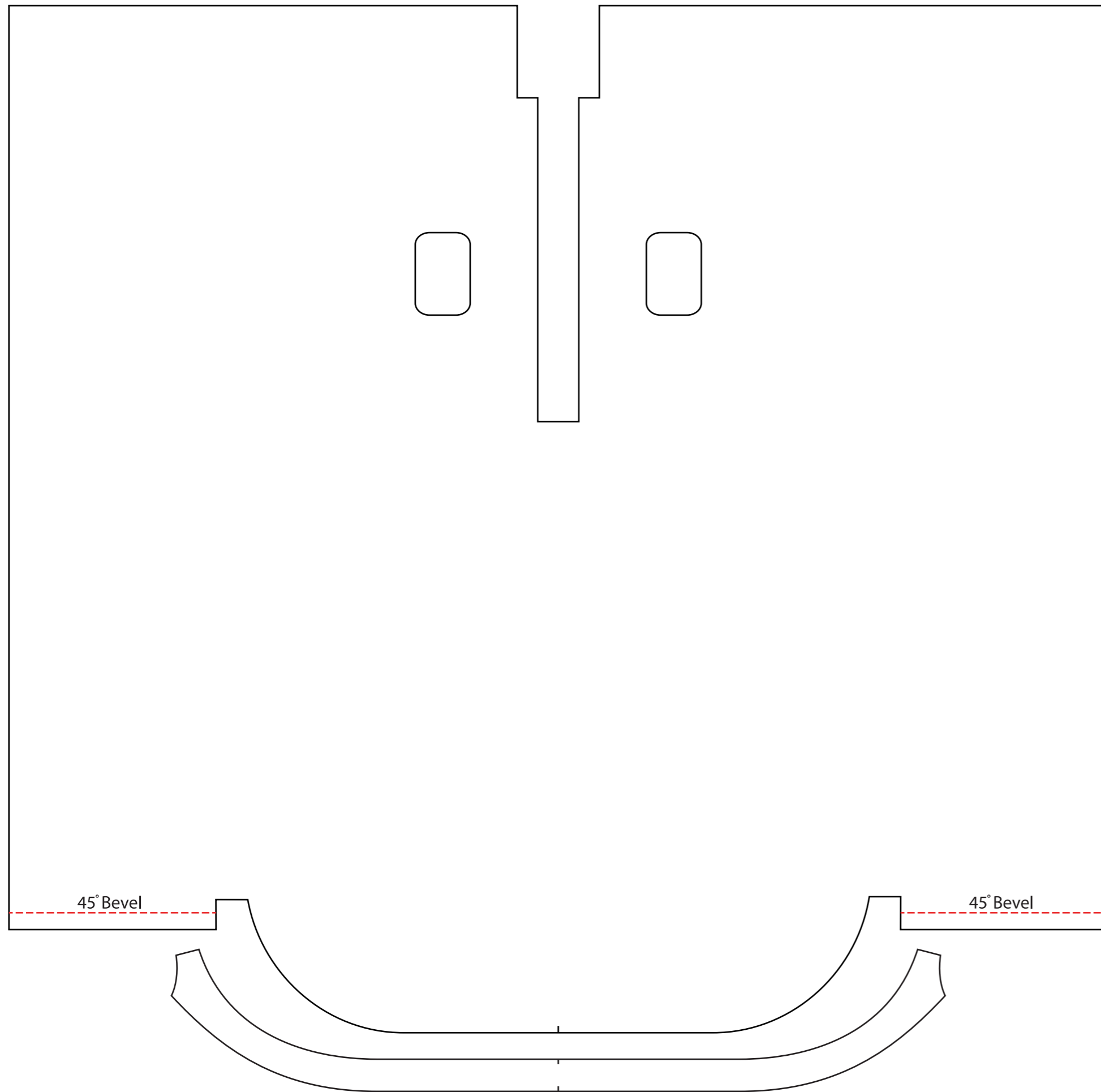

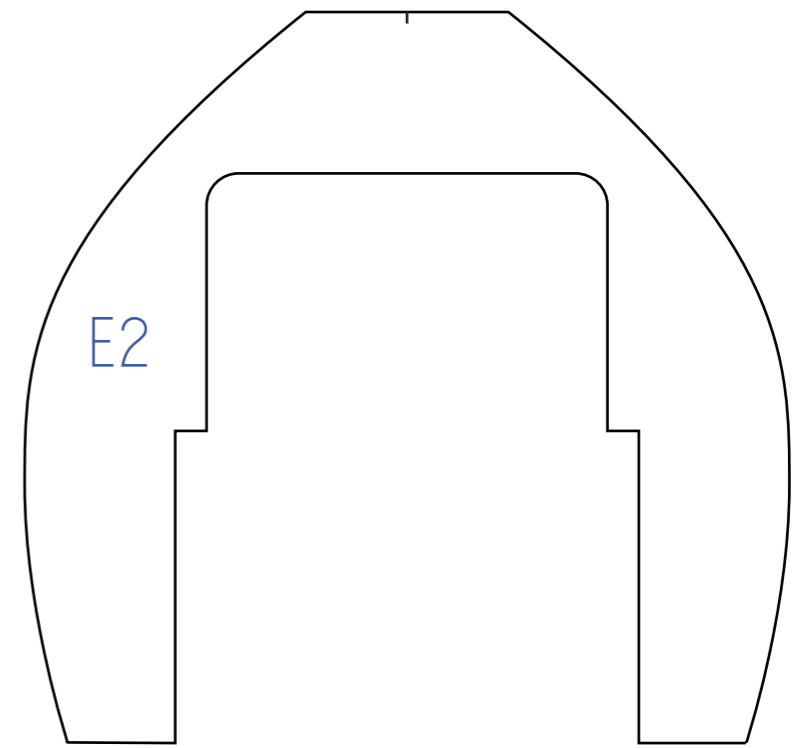
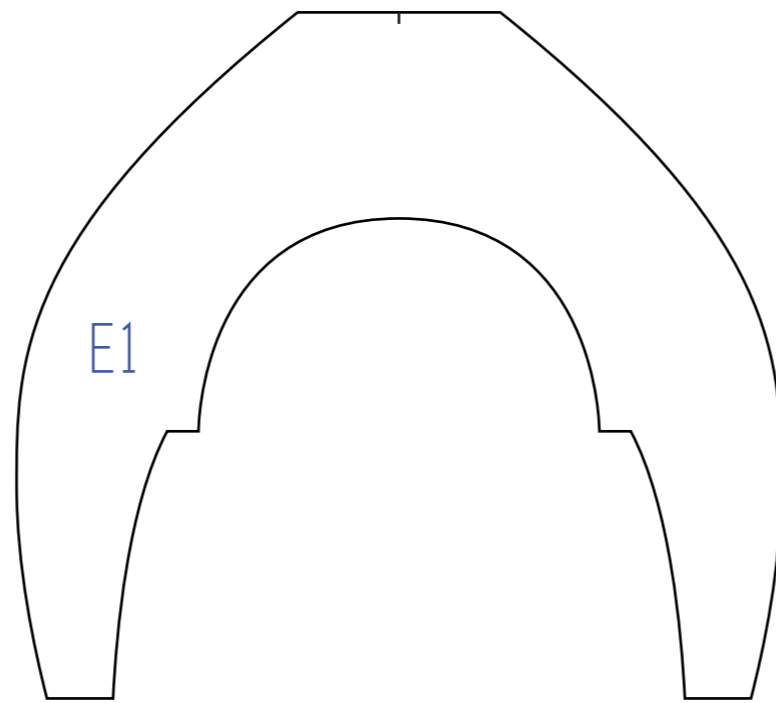
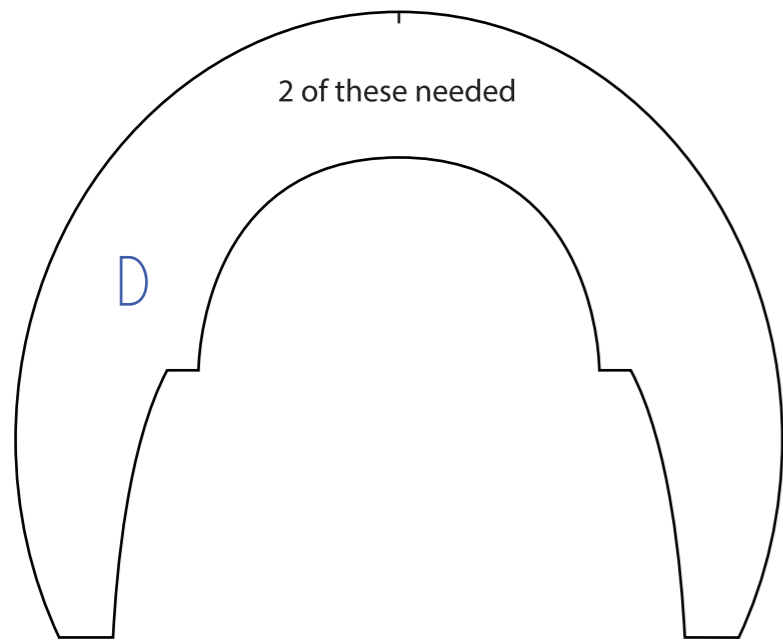
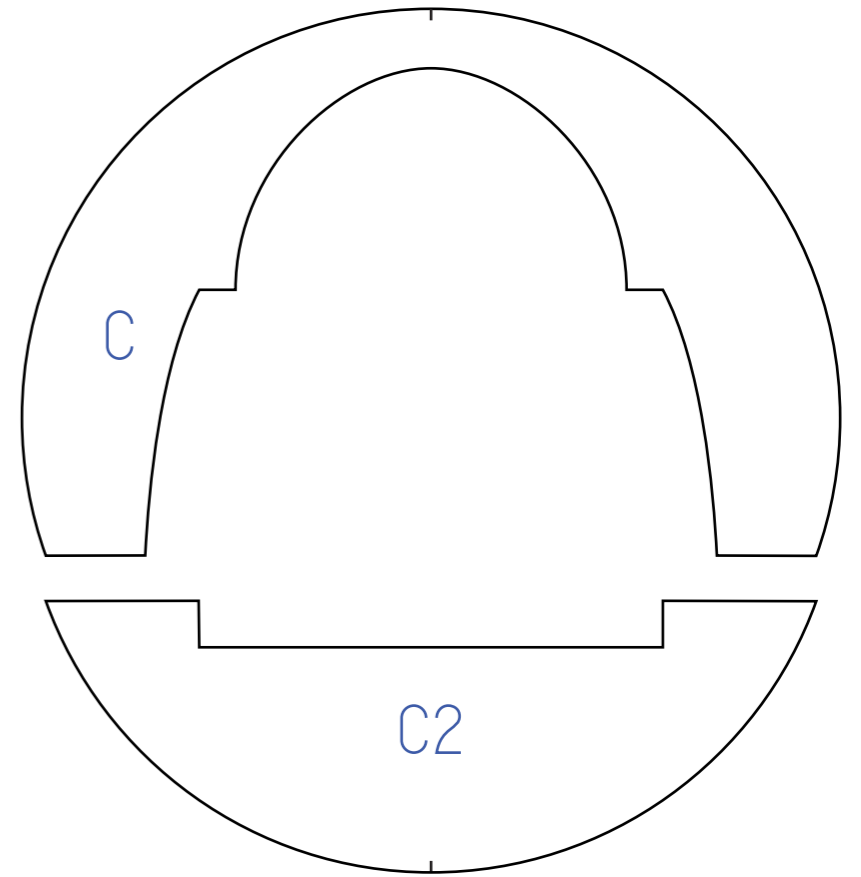
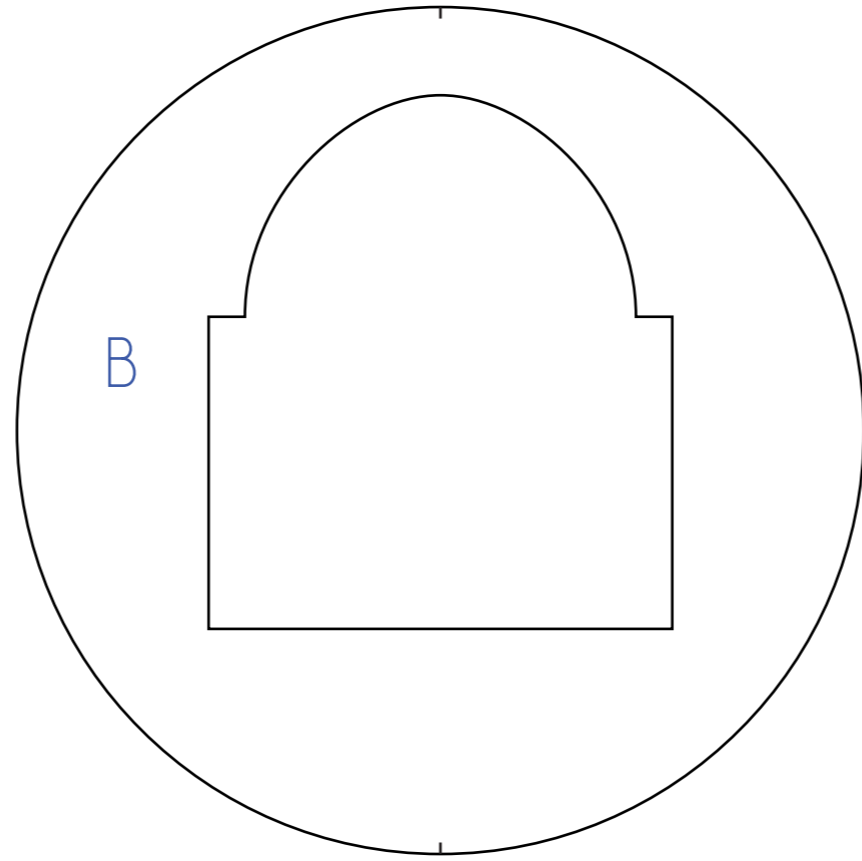
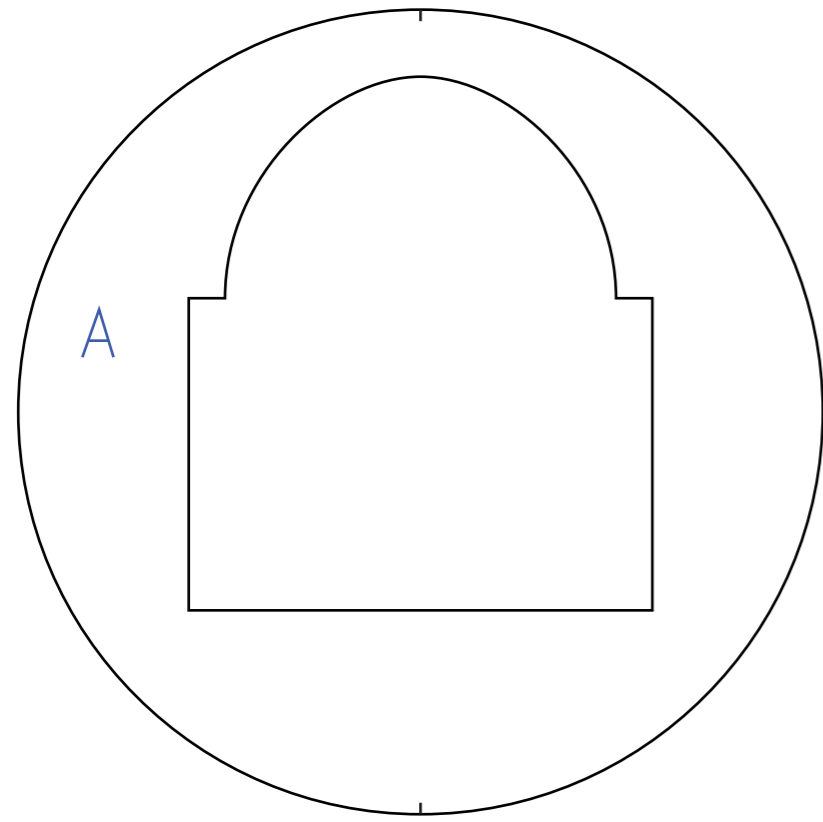

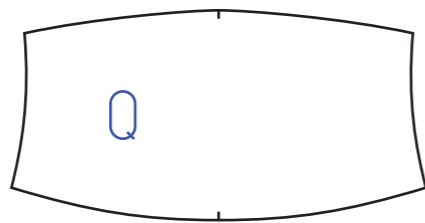
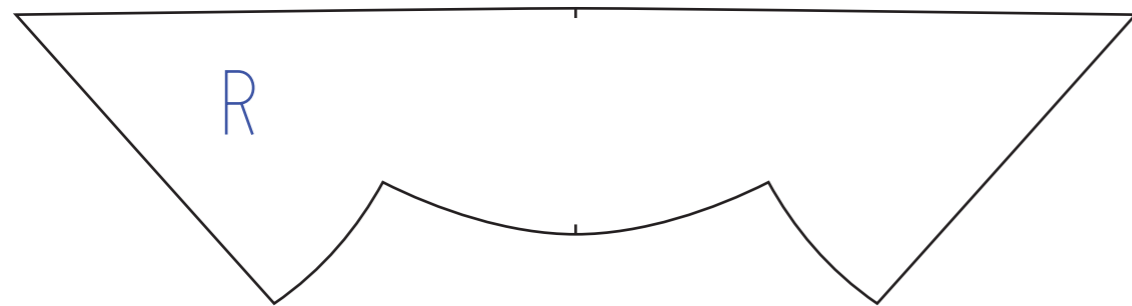
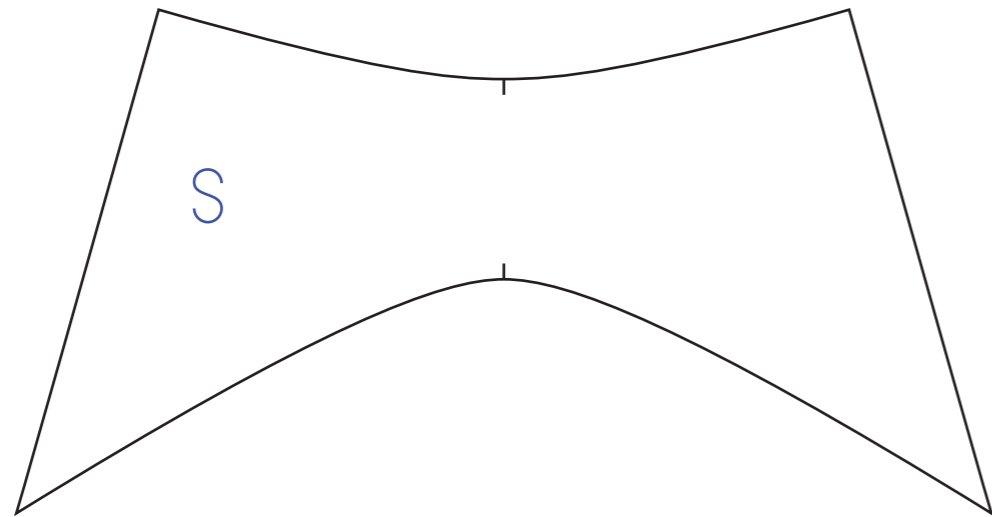

CANOPY
PIECES

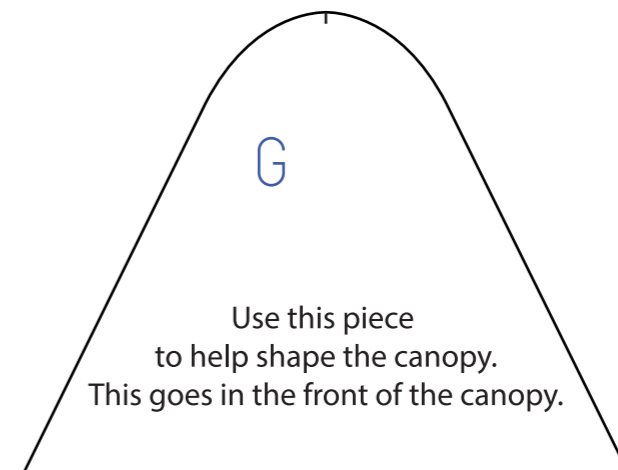
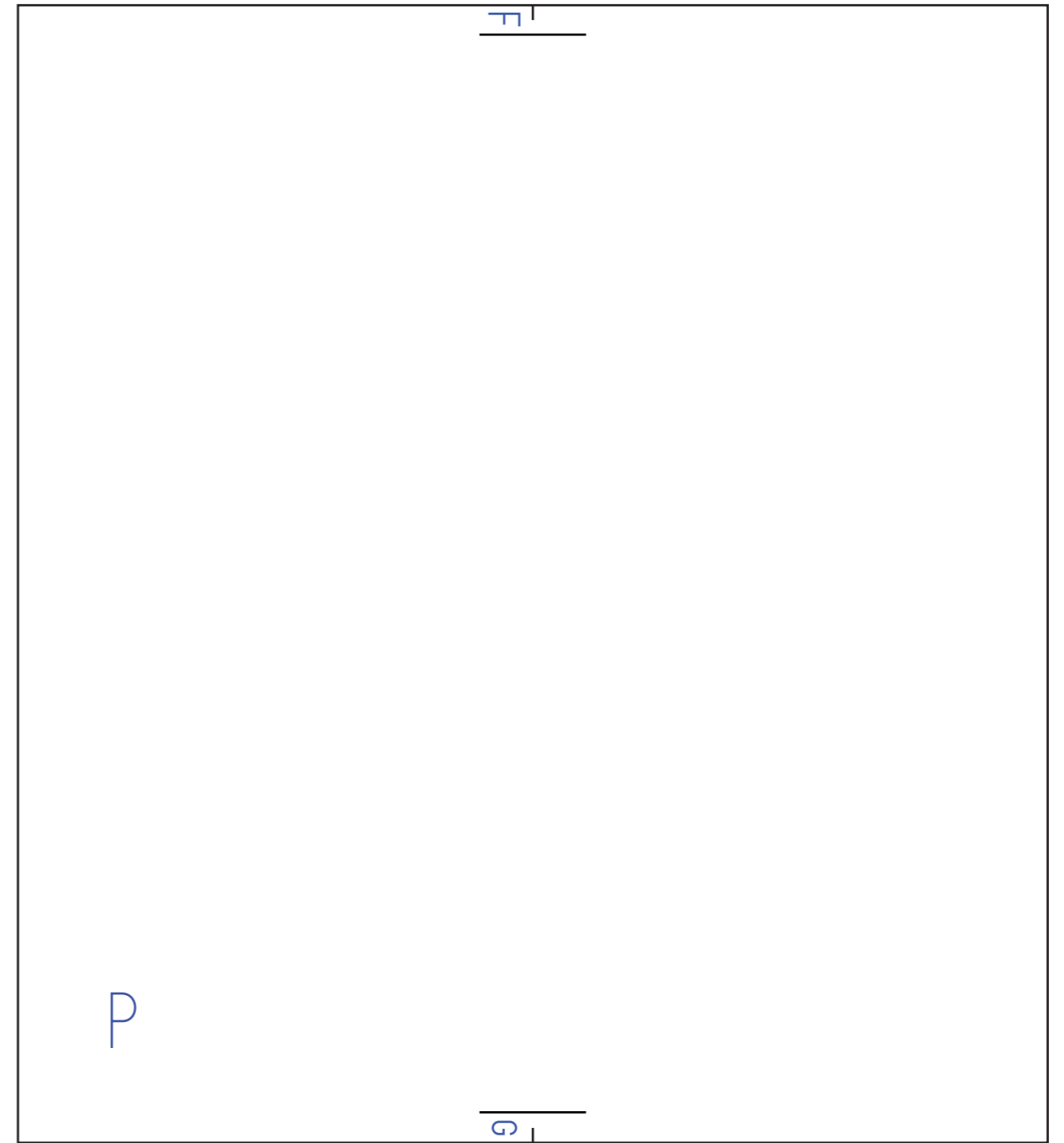
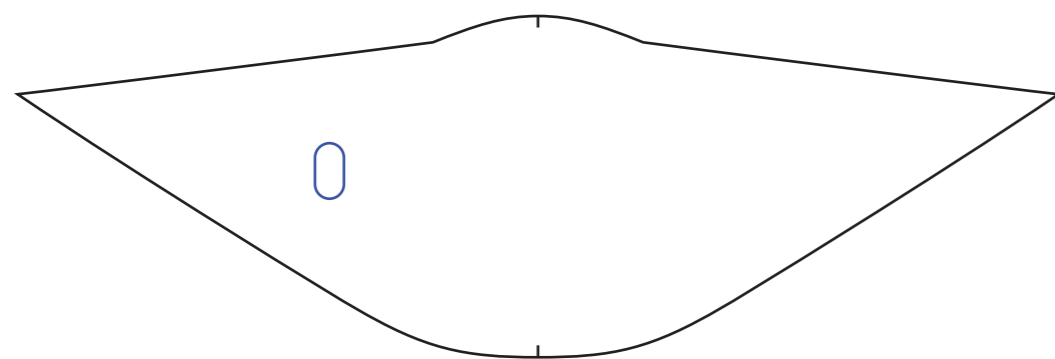

How to do the Leading Edges of the wings and elevator.

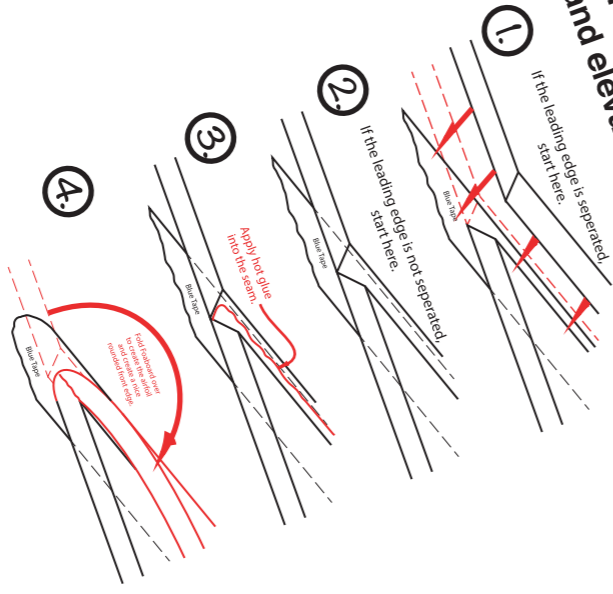

→ Cut a 45° Degree Bevel between the top wing and the lower wing before glueing.



Cut a 45° Degree Bevel between the top wing and the lower wing before glueing.

Copyright ©2021 13thSquadron. All Rights Reserved.
Commercial use of our plans are prohibited.

Piece
needed
for the
Hatch

M

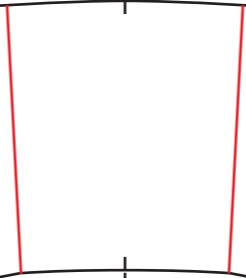

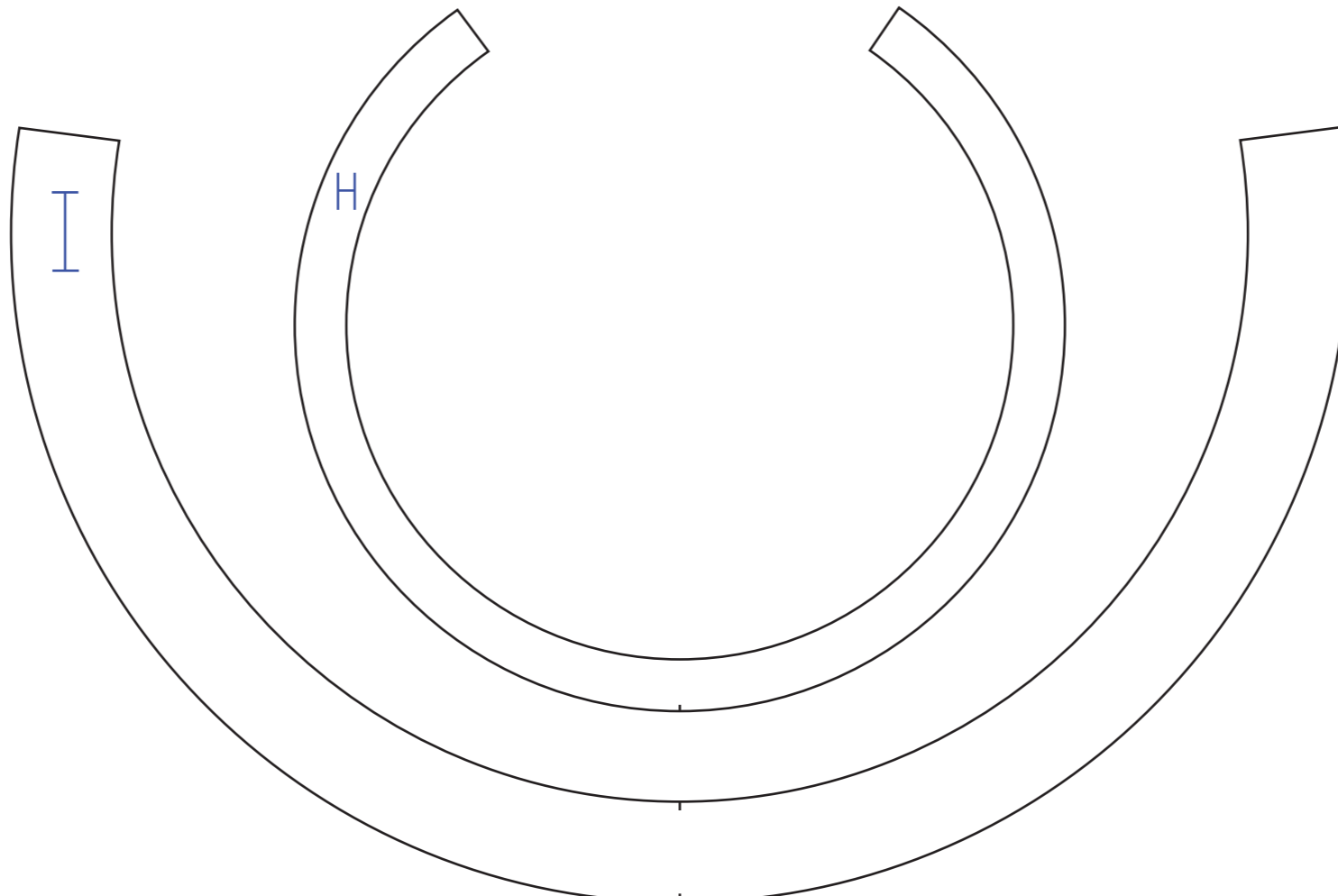
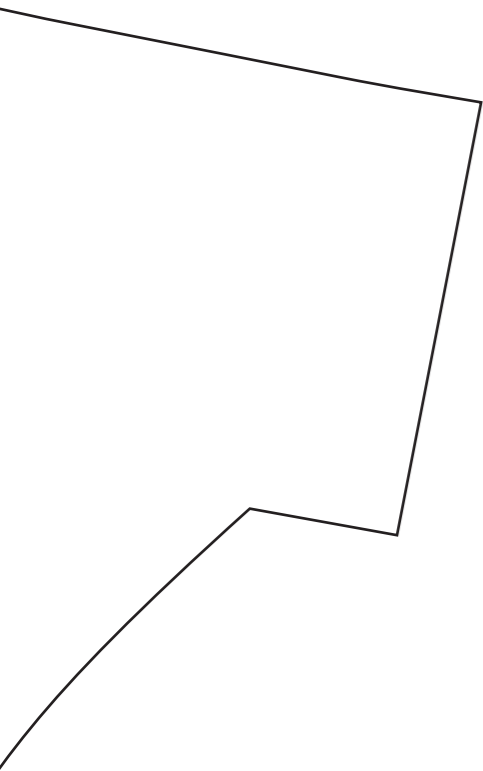

Nose Cowling Pieces

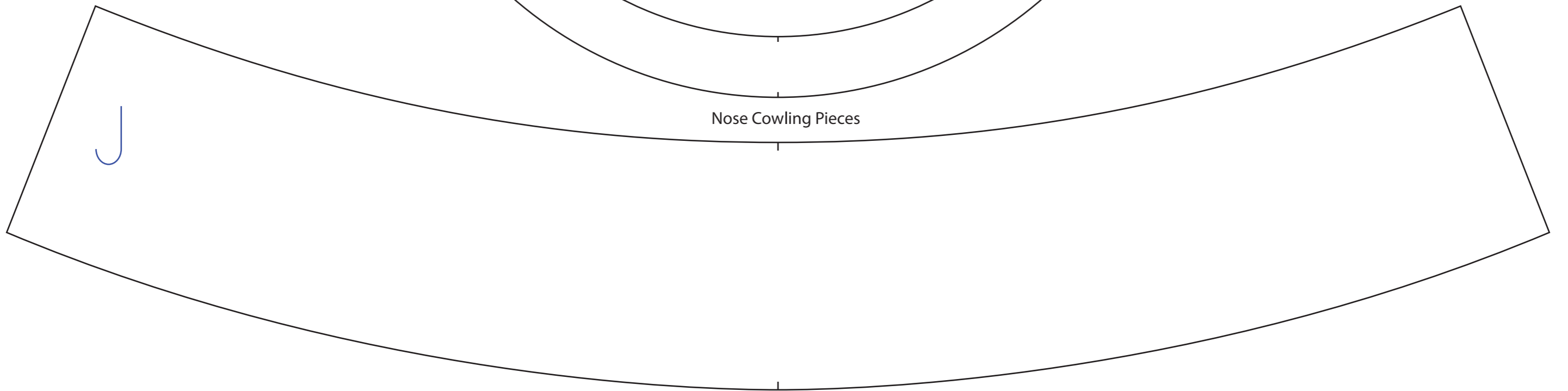

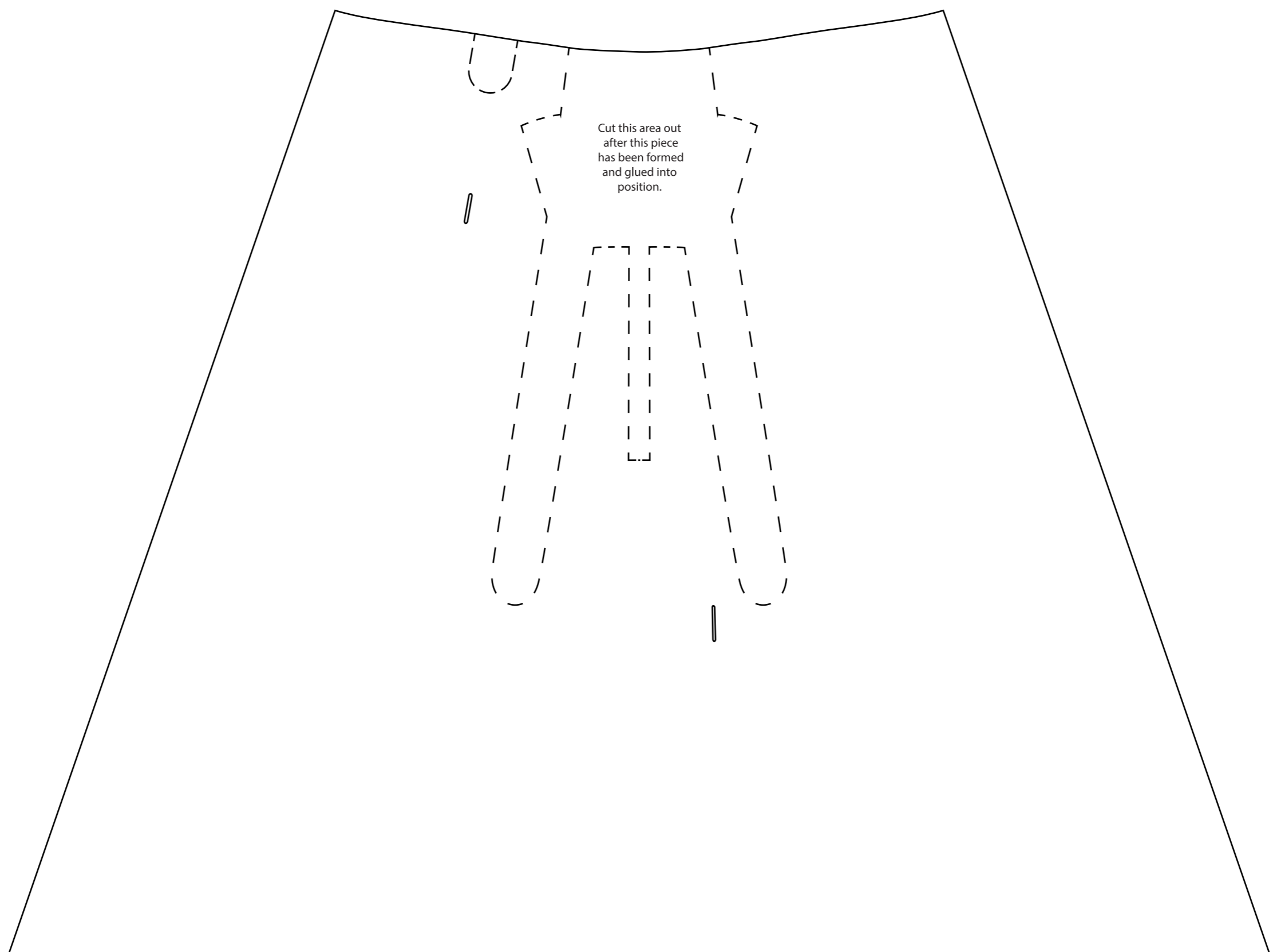

Cut this area out
after this piece
has been formed
and glued into
position.

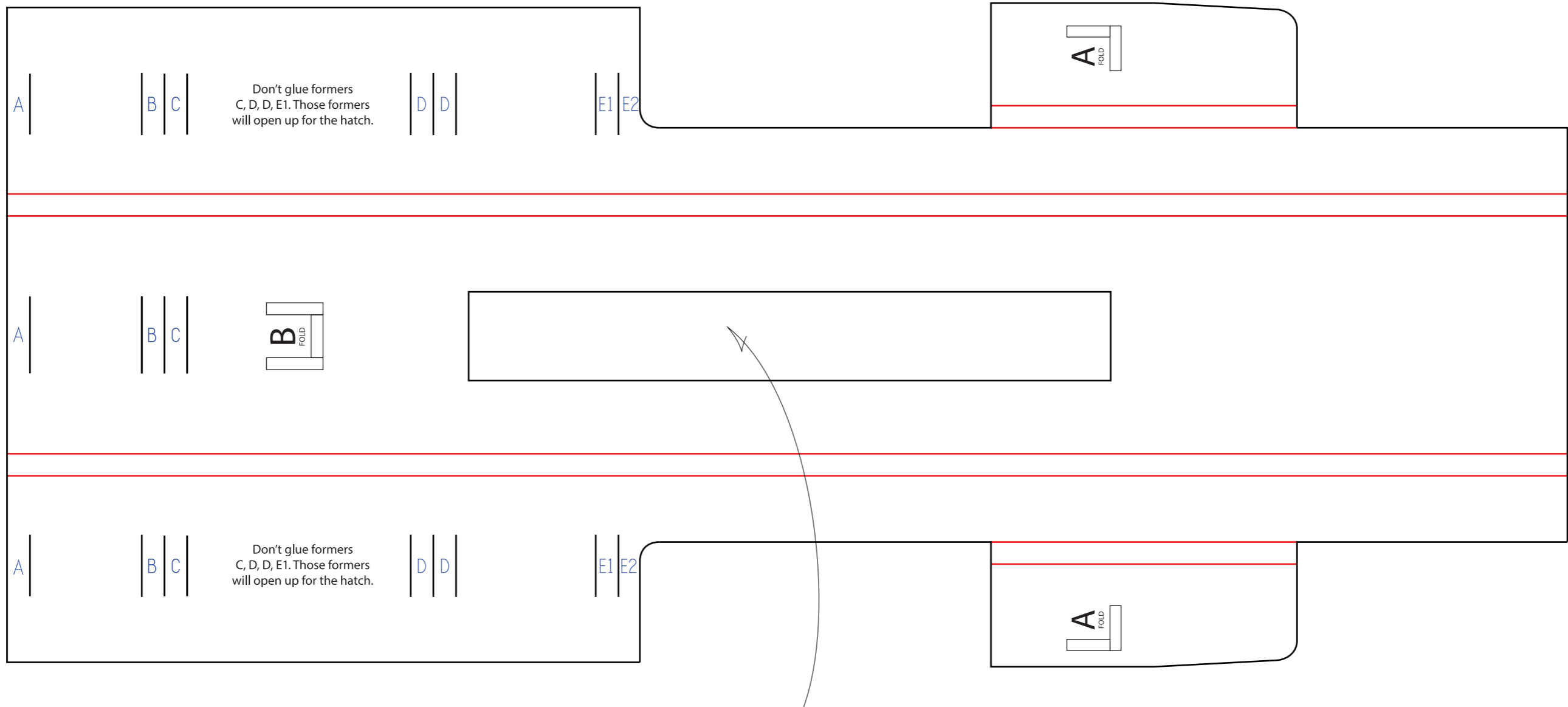

These pieces get glued together, and then gets glued here to the bottom of the box, to attach to the wing/airfoil.

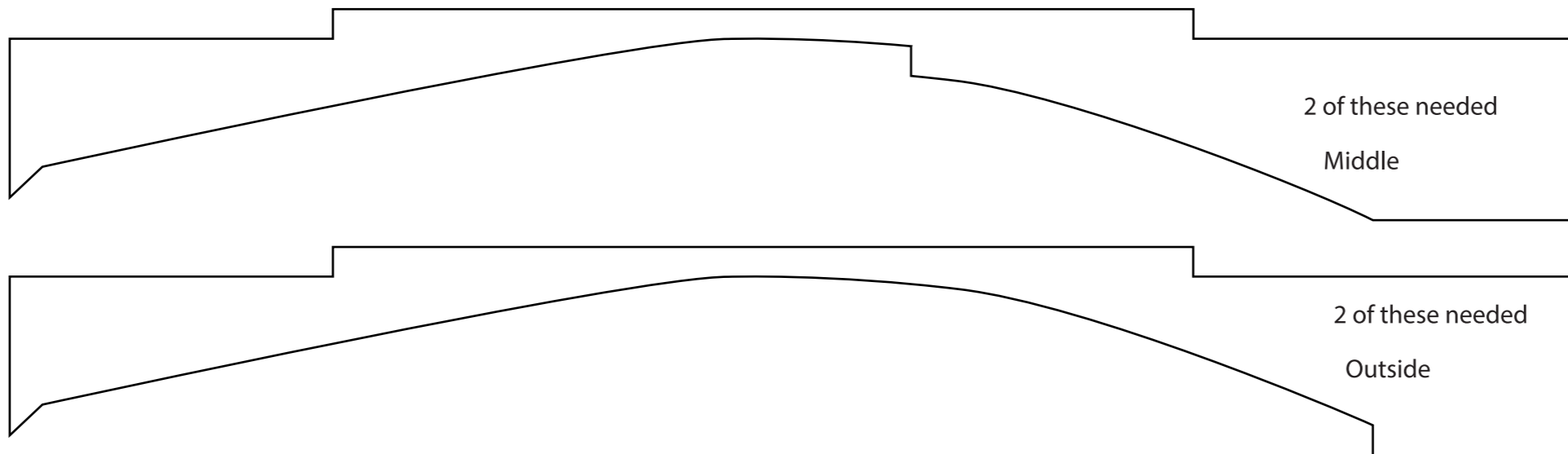

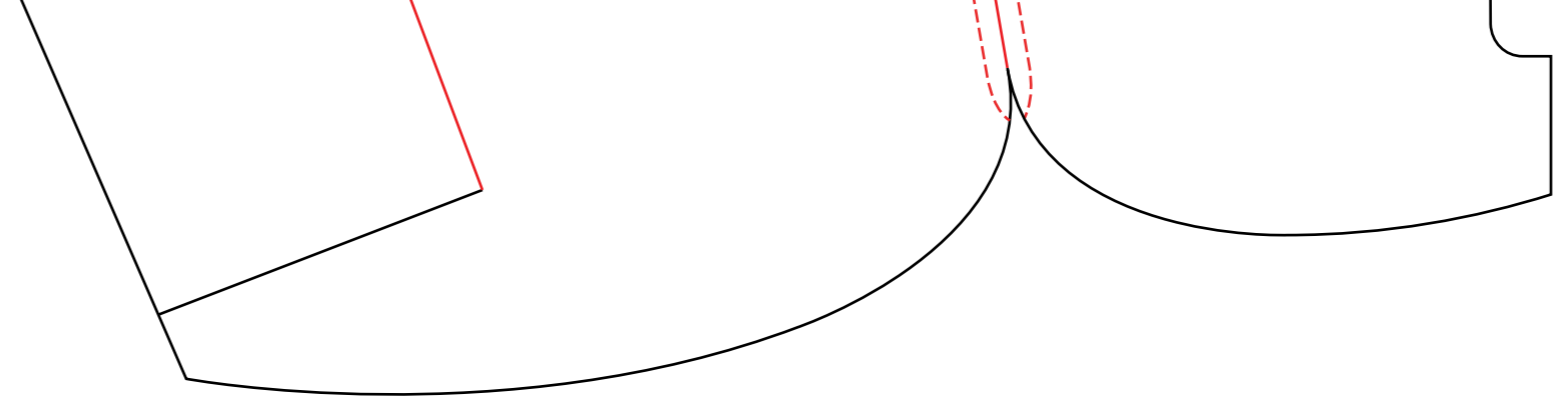

**USAF
ARMY**

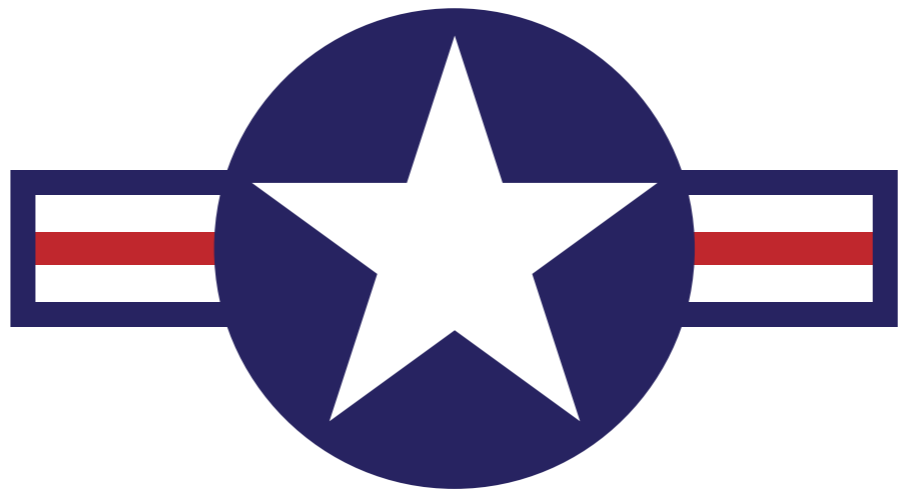

13

Lettering and Insignias you can use to put on your plane.

JN

0123456789

1234567890

ABCDEFGHIJKLMNOPQRSTUVWXYZ

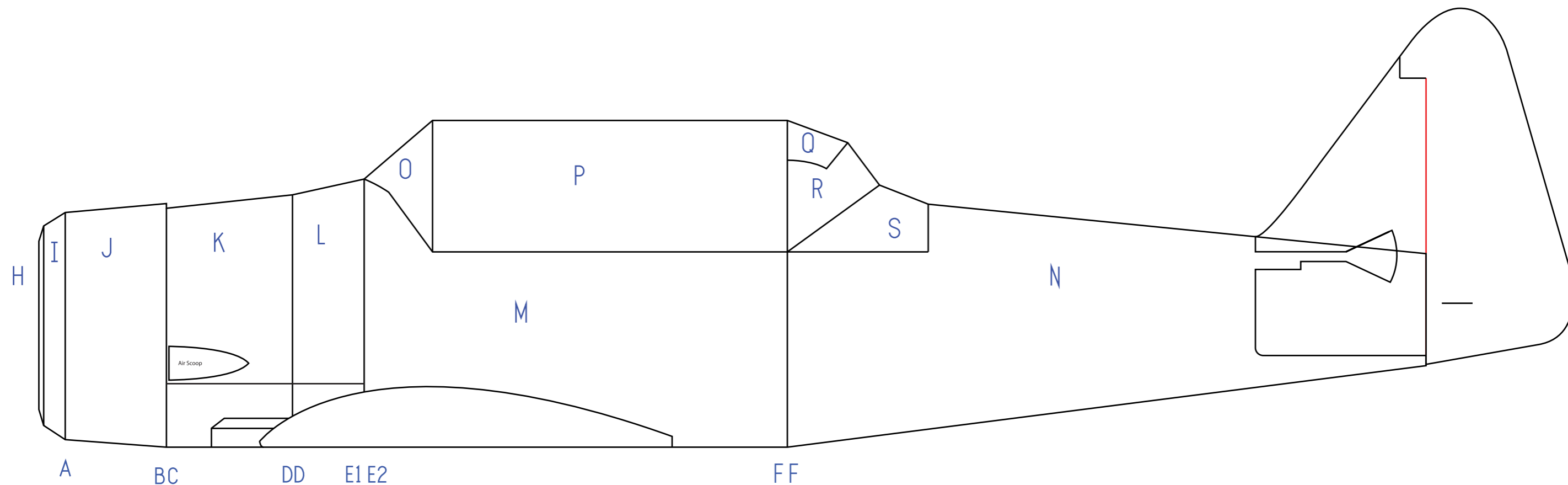

2218-1180kV Brushless Motor
“Flite Test C-Pack”
30-35 AMP ESC
4 channel receiver of choice
3 cell 1800 - 4 cell 2250
(4) 9 gram servos
Y-Harness
Servo Extension
9 x 6 or 10 x 4.5 Props
CG - 1 5/8” back from leading edge

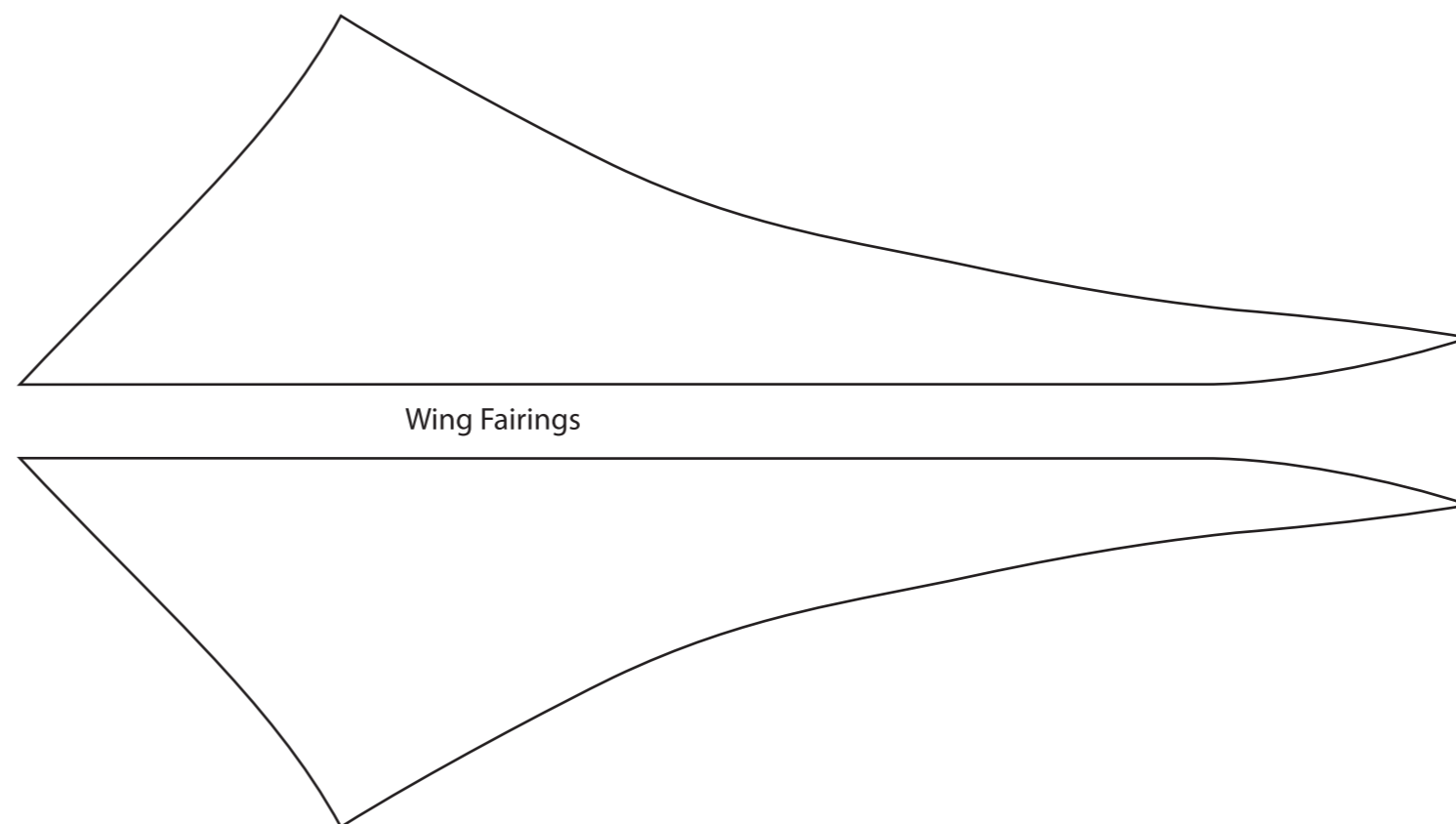

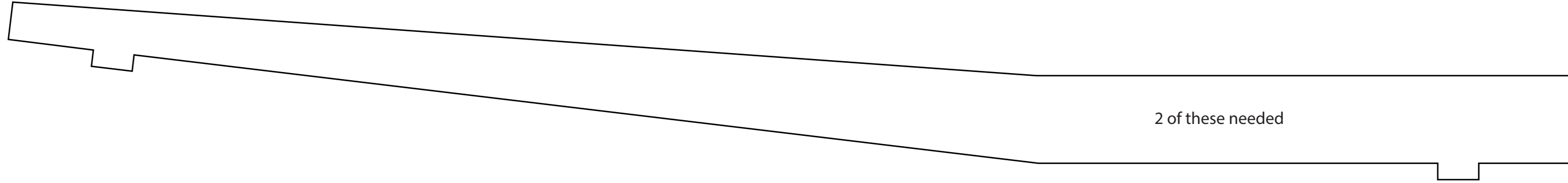
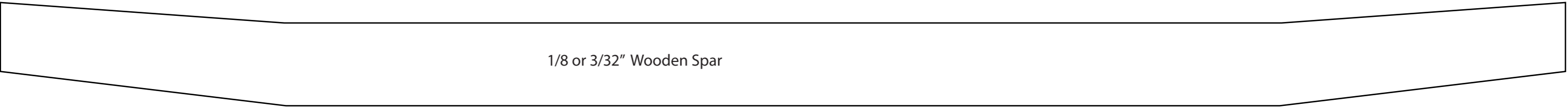
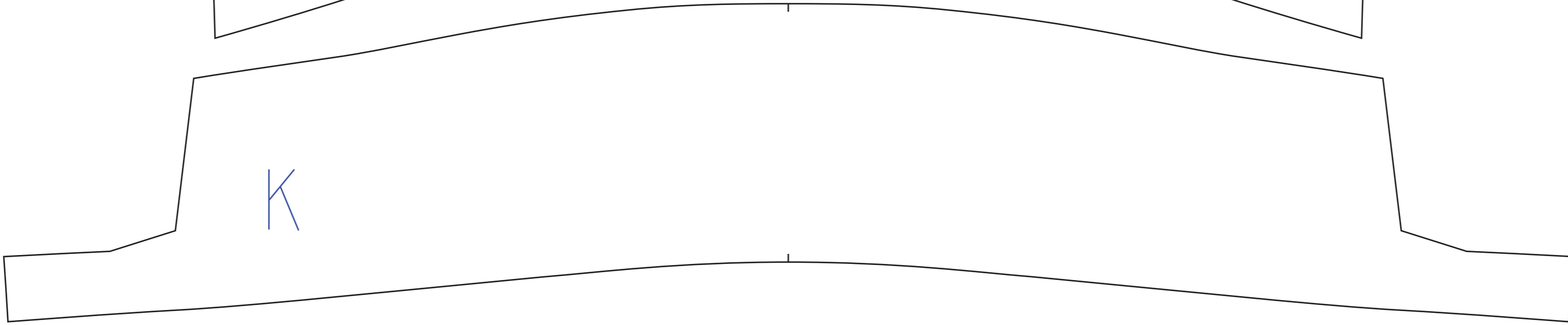
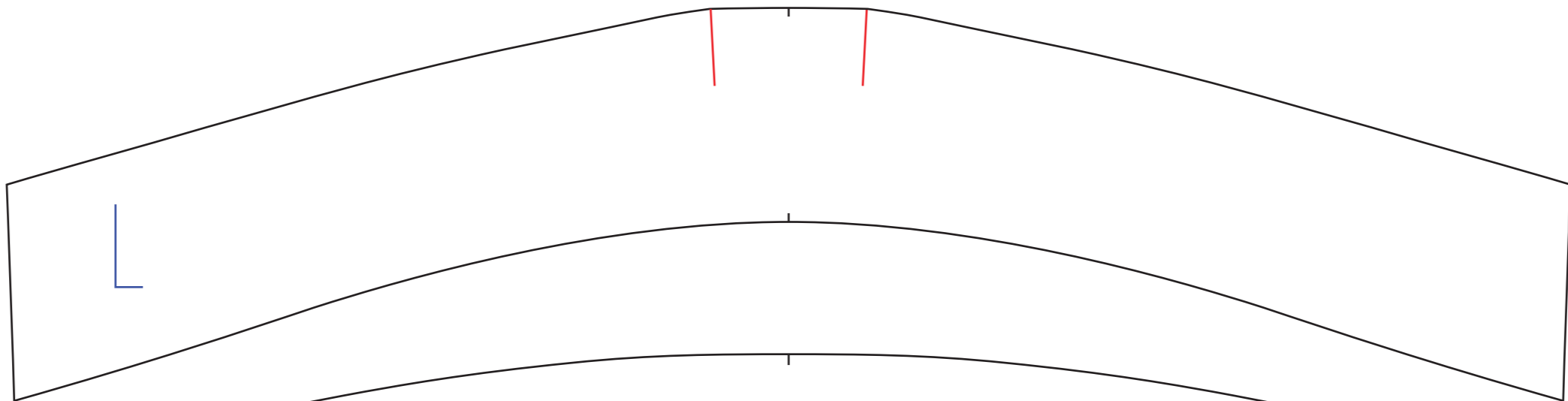

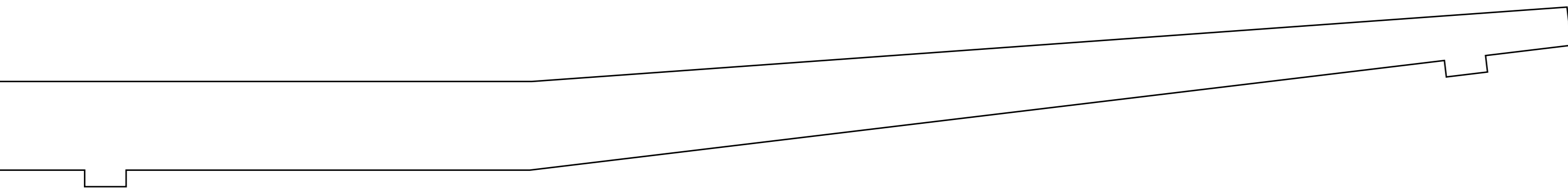
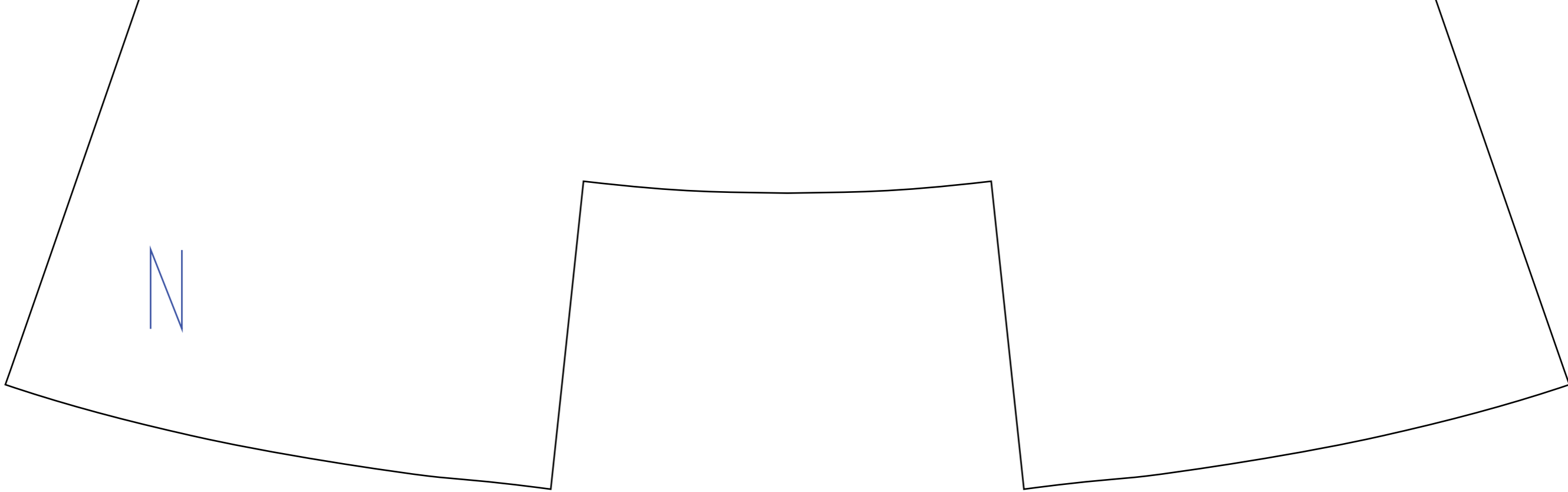

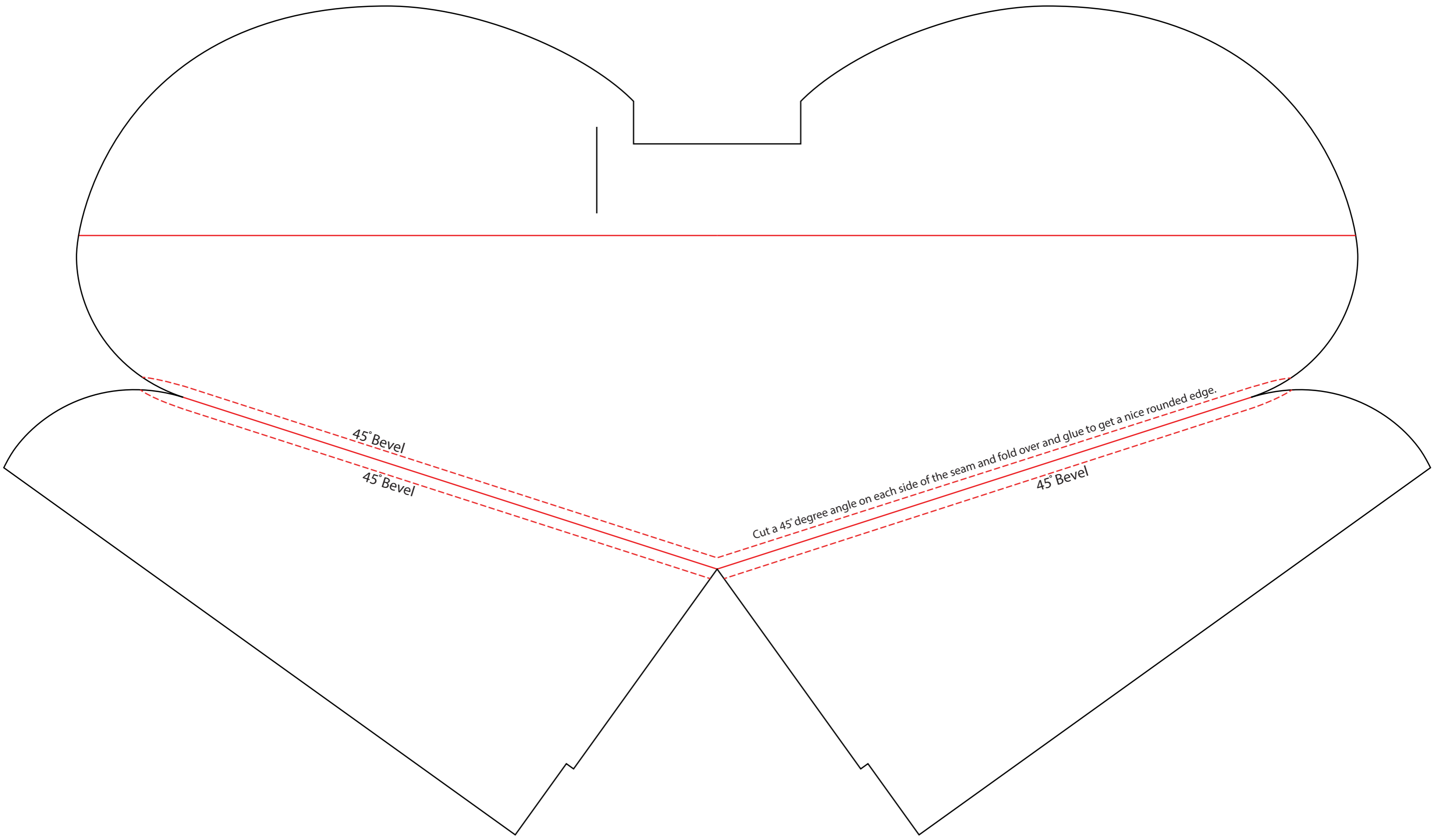

45° Bevel

45° Bevel

Cut a 45 degree angle on each side of the seam and fold over and glue to get a nice rounded edge.

45° Bevel